



Electricity Market Design and RE Deployment

(RES-E-MARKETS)

September 2016

ABOUT THE IEA RETD TECHNOLOGY COLLABORATION PROGRAMME

The IEA Renewable Energy Technology Deployment Technology Collaboration Programme (IEA RETD TCP) provides a platform for enhancing international cooperation on policies, measures and market instruments to accelerate the global deployment of renewable energy technologies.

IEA RETD TCP aims to empower policy makers and energy market actors to make informed decisions by: (1) providing innovative policy options; (2) disseminating best practices related to policy measures and market instruments to increase deployment of renewable energy, and (3) increasing awareness of the short-, medium- and long-term impacts of renewable energy action and inaction.

For further information please visit: <http://iea-retd.org> or contact info@iea-retd.org.
Twitter: @IEA_RETD

IEA RETD TCP is part of the IEA Energy Technology Network.



DISCLAIMER

The IEA RETD Technology Collaboration Programme, formally known as the Technology Collaboration Programme for Renewable Energy Technology Deployment, functions within a Framework created by the International Energy Agency (IEA). Views, findings and publications of IEA RETD TCP do not necessarily represent the views or policies of the IEA Secretariat or of its individual Member Countries.

COPYRIGHT

This publication should be cited as:

IEA RETD TCP (2016), *Electricity Market Design and RE Deployment (RES-E-MARKETS)* [Fabien Roques, Dmitri Perekhodtsev (FTI-CL Energy), Lion Hirth (Neon)], IEA Renewable Energy Technology Deployment Technology Collaboration Programme (IEA RETD TCP), Utrecht, 2016.

Copyright © IEA RETD TCP 2016

(Stichting Foundation Renewable Energy Technology Deployment)

ACKNOWLEDGEMENTS

The Authors would like to thank the IEA RETD TCP RES-E-MARKETS Project Steering Group (PSG) members for their guidance and support throughout the project, as well as the interview partners and supporting colleagues:

Project Steering Group

Louise Oriol	Ministère de l'Écologie, du Développement Durable et l'Énergie, France
Kristian Petrick	Operating Agent IEA RETD TCP
Michael Paunescu	Natural Resources Canada, Canada
Tracey Kutney	Natural Resources Canada, Canada
Simon Müller	International Energy Agency

AUTHORS

Fabien Roques, Dmitri Perekhodtsev (FTI-CL Energy, www.compasslexecon.com, froques@compasslexecon.com)

Lion Hirth (Neon Neue Energieökonomik GmbH, www.neon-energie.de)

Notice:

The views and analysis presented in this report are those of the FTI-CL Energy and Neon authors and not the views of FTI Consulting, Inc. or its management, its subsidiaries, its affiliates, or its other professionals. The authors of this work have used sources believed to be reliable in their efforts to provide information that is complete and generally in accord with the standards accepted at the time of publication. Neither the authors nor any party involved in the preparation or publication of this work warrants that the information contained herein is in every respect accurate or complete and do not assume responsibility for any errors or omissions or for the results obtained from use of such information. The authors expressly disclaim any express or implied warranty, including any implied warranty of merchantability or fitness for a specific purpose, or that the use of the information contained in this work is free from intellectual property infringement. This work and all information are supplied "AS IS." Readers are encouraged to confirm the information contained herein with other sources. The information provided herein is not intended to replace professional advice. The authors and the publisher make no representations or warranties with respect to any action or failure to act by any person following the information offered or provided within or through this work. The authors and the publisher will not be liable for any direct, indirect, consequential, special, exemplary, or other damages arising therefrom.



TABLE OF CONTENTS

1.	Executive Summary	1
1.1.	Study objectives	1
1.1.1.	Key challenges to power system with high shares of variable renewable energy sources	1
1.1.2.	Diversity of power systems and the implications for market design	1
1.2.	Policy recommendations.....	2
1.2.1.	High-level policy recommendations	2
1.2.2.	Recommendations for wholesale market design	4
1.2.3.	Recommendations for retail market design	6
1.2.4.	Conclusion and recommendations for further work	7
2.	Introduction: context and methodology	8
2.1.	Context and motivations for the study	8
2.2.	Objectives of the study	9
2.3.	Study approach	11
3.	A theoretical framework for market design assessment.....	13
3.1.	Introduction	13
3.2.	What is “power market design”?	13
3.2.1.	A definition of electricity market design	13
3.2.2.	Power market design a matter of public policy	15
3.2.3.	The different time frames associated with electricity market design	15
3.2.4.	Market design as a coordination and risk allocation mechanism.....	16
3.3.	Criteria for a benchmark ‘ideal’ market design.....	18
3.3.1.	High level criteria for the benchmark market design	19
3.4.	Diversity of power systems and the implications for market design	20
3.4.1.	The diversity of power systems and the challenges of high VRE shares	20
3.4.2.	Degree of unbundling and market liberalisation	21
3.4.3.	Physical characteristics of the system.....	21
3.4.4.	Power system prototypes considered	21
4.	Key challenges to power system with high shares of VRE	23
4.1.	Introduction	23
4.2.	Challenges of high shares of VRE to power systems and market design	23
4.2.1.	Capital intensity and low marginal cost.....	24
4.2.2.	Variability and limited predictability.....	29
4.2.3.	Decentralised and scattered generation.....	31
4.3.	Specific criteria for a benchmark market design with high shares of VRE.....	33
5.	Energy-only market.....	36
5.1.	Introduction	36
5.1.1.	Case study: energy-only market in Texas (ERCOT)	36
5.1.2.	Case study: energy-only market in Australia (NEM)	37
5.1.3.	Case study: European energy only markets.....	37
5.2.	Critical elements of the benchmark market design.....	37
5.3.	Design of the energy and ancillary services markets.....	38
5.3.1.	Benchmark market design	38
5.3.2.	Bridging the gaps	39
5.4.	Locational price signals	47
5.4.1.	Benchmark market design	47

5.4.2.	Bridging the gaps	47
5.5.	Development of hedging products	50
5.5.1.	Benchmark market design	50
5.5.2.	Bridging the gaps	51
6.	Vertically integrated utility	54
6.1.	Introduction	54
6.1.1.	Case study: vertically integrated system in South Africa	54
6.1.2.	Case study: vertically integrated utilities in United States	54
6.2.	Critical elements of the benchmark market design	55
6.3.	Regulatory framework	56
6.3.1.	Benchmark market design	56
6.3.2.	Bridging the gaps	57
6.4.	Rules for the third-party access	59
6.4.1.	Benchmark market design	59
6.4.2.	Bridging the gaps	59
6.5.	Trading arrangements with other utilities	60
6.5.1.	Benchmark market design	60
6.5.2.	Bridging the gaps	60
7.	Hybrid market	62
7.1.	Introduction	62
7.1.1.	Case study: hybrid market in Brazil	63
7.1.2.	Case study: hybrid market in Ontario	63
7.1.3.	Case study: hybrid market in United Kingdom	64
7.2.	Critical elements of the benchmark market design	65
7.3.	Integrated resource planning	66
7.3.1.	Benchmark market design	66
7.3.2.	Bridging the gaps	66
7.4.	Interface between centralised and decentralised processes	68
7.4.1.	Benchmark market design	68
7.4.2.	Bridging the gaps	68
7.5.	Organisation of mandatory risk hedging instruments	71
7.5.1.	Benchmark market design	71
7.5.2.	Bridging the gaps	71
8.	Prosumer market	75
8.1.	Introduction	75
8.1.1.	Case study: prosumer development in Germany	75
8.1.2.	Case study: prosumer development on other selected markets	77
8.2.	Critical elements of market design in prosumer markets	77
8.3.	Retail pricing and metering rules	78
8.3.1.	Benchmark market design	78
8.3.2.	Bridge the gap	83
8.4.	Regulation of distribution network operators (DSOs)	91
8.4.1.	Benchmark market design	92
8.4.2.	Bridging the gap	94
8.5.	Coordination of distribution grid and generation investments	95
8.5.1.	Benchmark market design	96
8.5.2.	Bridging the gap	96
8.6.	Market access for distributed generation	98

8.6.1.	Benchmark market design	98
8.6.2.	Bridging the gap	98
9.	Policy recommendations	101
9.1.	Cross cutting challenges associated with high shares of VRE and policy recommendations ...	101
9.2.	Wholesale market design policy recommendations.....	103
9.2.1.	Energy-only market policy recommendations.....	103
9.2.2.	Vertically integrated system recommendations	105
9.2.3.	Hybrid market policy recommendations	106
9.3.	recommendations for Retail market design.....	109
9.3.1.	Drivers determining the transition	110
9.3.2.	Prosumer market recommendations.....	112
10.	References	113
11.	Acronyms definition.....	117
	Member countries of the IEA RETD Technology Collaboration Programme	120

1. EXECUTIVE SUMMARY

1.1. STUDY OBJECTIVES

This report discusses electricity market design and regulation under high volumes of variable renewable energy sources (VRE) such as wind and solar power. We provide policy recommendations on how to reform current market and regulatory frameworks in order to accommodate high shares of VRE, in a timely, cost-effective and secure fashion. Recommendations differentiate between countries (or jurisdictions) that currently have liberalised wholesale markets and countries that do not.

1.1.1. Key challenges to power system with high shares of variable renewable energy sources

The evolution toward a power system with high shares of variable renewable energy sources (VRE) represents significant challenges for the functioning of the electricity markets and market design. The characteristics of VRE that provide challenges to power systems and markets if deployed at high shares include:

- **Capital intensity and low short-run marginal cost**, which makes cost recovery on energy-only markets more challenging due to increased price volatility and uncertainty, and makes market risk and capital market access even more important as a driver for electricity generation costs;
- **Limited predictability and variability**, which implies the thermal power plant mix needs to shift towards mid- and peak-load plants, that flexibility resources are present, that operational decisions are taken closer to real time, and that spot and system service markets need to be reformed to make this possible.
- **Decentralized and scattered generation**, which makes coordination between generation investment and (transmission and distribution) grid expansion more relevant, and makes it possible for small-scale assets to be operated by prosumers – a phenomenon that implies retail markets become a driver for investments in generation assets.

These characteristics of VRE raise a number of challenges to the evolution of the market design, such as:

- **Recovery of fixed costs** in a market where the marginal cost of production is generally low.
- **Ensuring the development of sufficient system flexibility** through the evolution of the market design.
- **Alignment of the time horizon for power system and market operations** in view of more variable and unpredictable VRE production closer to real time.
- **Evolution of the ancillary services markets** necessary for system stability.
- **Coordination of VRE and conventional production** with the available transmission and distribution network capacity.

1.1.2. Diversity of power systems and the implications for market design

Real-world electricity market design is diverse, complex, multi-level and path-dependent, ranging from liberalised markets to integrated utilities, from very flexible power systems to very inflexible systems. In addition, policy makers' approaches to energy policy ranges from those favouring high degree of regulatory intervention and detailed steering to others who leave a wider range of decisions to the market. Therefore, it is unlikely that one perfect "silver bullet" market design solution would respond to the challenges of high shares of VRE in all jurisdictions given the diversity of local circumstances.

To address this diversity in a transparent way, **we study four power system prototypes that allow us to focus on specific aspects of market design**. Each real-world electricity market represents a combination of these prototypes.

The four power system prototypes that we selected **differ in the degree of centralisation and the role of market prices (either from wholesale or retail markets) versus separate out-of-market coordination mechanisms** in the decision-making process for both short term plant dispatch and long term for investment and retirement decisions:

- **Energy-only market**, where generating capacity investments and short term operations are mostly driven by market signals in the energy and ancillary services markets.
- **Vertically integrated utility**, where both the short-term and the long-term decisions are centralised by the incumbent vertically integrated utility.
- **Hybrid market**, where dispatch decisions remain based on wholesale power prices, but generator investment decisions are supplemented by additional risk transfer or coordination mechanisms induced by the policy maker.
- **Prosumer market**, where a significant share of generators is located with consumers. The wholesale market can be either organized as an energy-only market, as a vertically integrated utility, or as a hybrid market. In this sense, prosumer markets are cross-cutting.

For each of the power system prototype we analyse the market design challenges based on the specific **experiences of jurisdictions that share a number of key characteristics with the respective prototypes** as detailed in Table 1.

	Energy-only	Vertically integrated	Hybrid	Prosumer
Dispatch decisions	Decentralised through wholesale market prices	Centralised based on costs and other drivers	Decentralised through wholesale market prices	Decentralised through retail market prices
Investment generation	Decentralised through wholesale market prices	Centralised based on planning	Centralised based on planning and/or risk sharing mechanism	Decentralised through retail market prices
Examples	Texas, Australia, Europe	South Africa, US	Brazil, UK	Germany, Australia, California

Table 1: Power system prototypes depending on the degree of decision centralisation

Source: FTIC-CL and Neon

1.2. POLICY RECOMMENDATIONS

Whilst there is no silver bullet market design, this report provided both high level policy recommendations that are valid in general, as well as more specific policy recommendations for some key power market prototypes in the wholesale and in the retail markets.

1.2.1. High-level policy recommendations

Regardless of the market prototype, a policy maker may need to address three main areas to ensure a smooth transition to a system with high share of VRE:

- Short-term system operations;
- System development and investment; and
- Governance and regulatory framework.

Recommendations for short term system operation

Large shares of VRE imply that the **power system will need to be balanced closer to real time**, which requires a **market design that appropriately reflects short term system operation costs**. Therefore, the market design of the short-term markets and ancillary services should evolve in the following direction:

- Remove barriers preventing power prices from convey the high value of electricity at times of scarcity.
- Ensure that the market design creates a level playing field and fosters the development of flexibility in its various forms (storage, demand side management (DSM), new cross border lines etc.).
- Introduce locational signals to coordinate in real time many decentralised players and transmission and distribution networks, either through the implementation of nodal/zonal prices or through local markets for ancillary services.
- Develop new risk hedging and risk transfer mechanisms specifically tailored to the new types of risks, e.g. hedging products for intraday / balancing price volatility.
- Revisit the optimal mix of decentralised (price based) and centralised (planned) steering mechanisms.

Recommendations for optimal system development and investment

A power system with large shares of VRE creates a number of **challenges for investors, in order to manage the capital intensity, fixed cost recovery issues, and risk exposure**. To meet these challenges, the market design evolution should include:

- Policies supporting the development of efficient risk transfer and risk hedging mechanisms will be needed to ensure the financeability and bankability of capital intensive technologies and to reduce the cost of capital.
- The market design should introduce long-term coordination mechanisms for the decision on siting and timing of investment across centralised / decentralised generation capacity and network expansion.
- A regulatory framework of the network development should evolve to include necessary elements of incentive regulation to drive efficient and timely development of the grid infrastructure.

Recommendations on governance and regulatory framework

The rise in the share of VRE technologies will require **changes in the governance and regulatory framework** in a consistent way with the market design:

- Policies supporting technological innovation and smart, unconventional solutions are needed. In particular, the regulatory framework for the transmission, distribution and market operators needs to incorporate incentives for innovation and investments in smart grids. Policy makers might consider the creation of a new independent regulatory agency with proactive mandate to drive the transition.
- An efficient allocation of responsibilities between the different geographic levels of governance is warranted. This may require revisiting the role of the TSO / ISO, as well as the interface and responsibilities of the TSO and DSOs. In addition, an efficient governance of energy at a local level and interface with the national and regional levels needs to be put in place.

1.2.2. Recommendations for wholesale market design

Depending on the current organisation of the wholesale power system (market prototype), policy makers may need to focus on different areas of the reform of regulatory, policy and market framework. We present below the policy recommendations for the energy-only, vertically integrated market prototypes, as well as the hybrid market prototype.

The presence and the **speed of development of flexible resources** as well as the **willingness of policy makers to intervene to support specific technologies or ensure security of supply** are among the key drivers determining whether some **incremental reforms** to the current short run marginal cost (SRMC) based power markets will be sufficient or **whether more radical reforms to introduce hybrid power markets** with out-of-market risk hedging and coordination mechanisms will be required.

Energy only market policy recommendations

In an **energy-only market**, a policy-maker should address three areas of market design that are critical and may need evolution at high VRE shares:

- **Implement market design elements ensuring accuracy of short-term price signals.** The short-term markets should value electricity and flexibility produced by different power plants and flexibility resources in a time frame which is sufficiently close to real-time to account for changes in the wind and solar forecasts and to reflect the real-time scarcity situations. Significant changes in the market design will be required to ensure these prices remain an accurate indicator of value of energy in the short run and a reliable signal for investment in the long run: removing barriers to scarcity pricing, while properly addressing market power and market abuse, improving balancing and operating reserve markets and allowing DSR participation in all market segments.
- **Introduce locational price signals to provide incentives for coordinated development of generation and network.** Increasing distance between generation and consumption resulting from the increased VRE shares require better geographic coordination of plant dispatch and better coordination of generation and transmission investments. Such coordination can be achieved through a range of locational price signals from zonal and nodal energy prices to various injection and interconnection transmission tariffs.
- **Develop hedging products.** Higher capital intensity and price variability induced by high VRE shares would increase the need for investors to be able to lock-in the increasingly variable market revenues in advance. Measures to improve opportunities for voluntary forward hedging could involve introduction and emerging of new standard products for over-the counter trading as well as power exchanges.

Vertically integrated system recommendations

In a **vertically integrated utility**, a policy-maker should address three different areas of market design are critical at high VRE shares:

- **Adopt an efficient regulatory framework.** A vertically integrated utility makes its operating and investment decisions under the framework imposed by the regulator. Efficient operation under high share of VRE may require implementing incentive regulation mechanisms to foster deployment of low carbon technologies to support the development of the enabling infrastructure, as well as sources of flexibility such as storage, DSM, etc. The regulation framework may delegate the planning role to a neutral third party (e.g. an ISO), possibly with a regional scope of planning responsibilities.
- **Apply transparent and non-discriminatory rules for third-party access.** RES investment is often provided by Individual Power Producers (IPPs) rather than the incumbent monopolist. Rules for third-

party access may include RES-specific measures, such as facilitating regulatory approval and streamlining network connection procedures. Planning and licensing procedures could be adapted to meet the specific requirements of renewables projects. The third-party access arrangements may go beyond the requirements for the incumbent to provide third-party access and delegate connection and dispatch roles to a neutral third party, such as an independent regulatory agency or an ISO.

- **Facilitate cross-border trading arrangements.** High shares of RES may require increased volumes of power trading with neighbouring areas to leverage flexibility existing cross-border to facilitate balancing of RES. This would require vertically integrated systems to implement regulation and legal frameworks allowing bilateral cooperation on electricity trading as well as regional cooperation to ensure secure operation of the electricity system. This may require implementing a regional coordination agency, with a mandate to optimize system operation on a regional basis.

Hybrid system recommendations

The challenges presented by high shares of VRE for market design may require **introduction of hybrid system elements, combining the centralised and decentralised approaches** for either the short-term system operation and / or the long-term system development. Two general types of hybrid systems can be identified:

- Support to flexible capacity is done through a capacity or flexibility remuneration mechanism that would aim to deliver a target level of security of supply, and to give providers of flexible capacity additional remuneration;
- A two-step hybrid market (an investment market in the first step and a short term spot markets operation in the second step) with either (i) a technology-neutral investment tendering first phase or (ii) a technology-specific investment market involving tenders by category of RES and complimentary flexible technologies.

Policy makers should make a choice on the best hybrid approach depending on their own preferences for decentralisation (market-based price signals) and centralisation (central planning / coordination mechanism) of decisions in matters of energy policy, and the flexibility of the system provided by storage, DSM and interconnection.

Once the decision on a type of a hybrid market is made, policy makers should address the following three areas of market design that are critical with high VRE shares:

- **Ensure efficient integrated resource planning.** The integrated resource planning process needs to achieve an efficient and timely development of VRE and other sources of energy and flexibility. An efficient resource planning process is facilitated by an independent planning agency with a clear mandate, adequate incentives, and sufficient information and expertise.
- **Carefully design the interface between centralised and decentralised processes.** The specific feature of the hybrid market is the co-existence of the market-based decentralised process for energy dispatch and a centralised process for the investment. One needs to ensure that the long term contracts serving as mandatory risk sharing instruments do not associate payments with short-term operation, such as production of energy or ancillary services. Any such association would inevitably distort incentives for efficient short-run operation, which is specifically important under the high shares of VRE.
- **Award mandatory risk hedging contracts through transparent auctions.** The centralised process driving investment in the hybrid markets can be based on various types of mandatory risk-sharing mechanisms. These risk-hedging contracts should be awarded through a transparent auction-based procurement process to minimize costs and encourage participation of a range of technologies.

1.2.3. Recommendations for retail market design

Development of high shares of VRE is associated with development of the prosumer market, that is, customers that are active in production on their consumption site. Such auto-production is often done from variable renewable sources, such as solar PV.

Policymakers should first understand the drivers of the development of the prosumer market. In our view, three broad drivers of a prosumer market development exist:

- Spontaneous prosumer market development with consistent wholesale and retail prices;
- Prosumer development requiring monetary incentives through dissociation between wholesale and retail prices; and
- Prosumer development induced through energy service bundles sold to customers by aggregators.

Moreover, the prosumer development path will depend **on the consumers' engagement and the way electricity is sold in the retail market**. In particular, the development of high shares of VRE may result in electricity sold to the end user as a service bundle rather than a commodity where customers pay per kWh of consumed energy. The potential **shift away from a commodity pricing approach for retail electricity toward service-based approach**, as well as the **level of engagement of consumers will drive the speed and magnitude of the required market reforms**.

Once the policy maker is set on the development path of the prosumer market as outlined above, it will need to focus on four areas of market design are critical for high wind and solar penetration:

- **Adapt retail pricing and metering rules to account for their new role as investment incentive.** Consumers make consumption and investment decisions based on price signals they receive through retail electricity tariffs, rather than wholesale electricity prices. The effective price received for self-consumed electricity depends on the level and structure of retail prices and on the way consumption is measured (e.g., net metering). The fact that the retail price provides the investment signal for prosumers can be problematic for three reasons: investment incentives might be distorted vis-à-vis non-prosumer investments; prices might fail to signal system needs; and the income of governments and system operators might decline. Possible responses to these challenges include the alleviation of retail prices from charges and taxes, more cost-reflective grid tariff structures, and/or the taxation of self-consumed electricity.
- **Redesign regulation of distribution network operators (DSOs) with focus on (smart) investments.** Small-scale prosumers are typically connected at low voltage levels to the distribution grid. Auto-generation as well as other demand-side participation in electricity markets often requires upgrading distribution networks. Smart grid technologies can often help to contain costs. Regulation should focus more on investment incentives and innovation.
- **Provide locational signals to investors within distribution grids.** An important means to limit distribution grid costs is to coordinate generation and grid investments. This requires some signal to prosumer investors where and where not to invest; such signals have traditionally not existed in all jurisdictions. Developing a feasible mechanism to reflect grid costs and provide efficient signals to grid users and investors is of critical importance.
- **Provide market access and apply balancing responsibility.** Unlike large-scale generators, prosumers access wholesale markets through intermediaries, or aggregators. A good market design assures low-cost market access, competition among aggregators, and balancing responsibilities to prosumers.

1.2.4. Conclusion and recommendations for further work

The evolution toward a power system with high shares of VRE represents significant challenges for market design. Whilst there is no silver bullet market design, this report provided both high level policy recommendations that are valid in general as well as more specific policy recommendations for some key power market prototypes.

As regard to the wholesale market, the speed of development of flexible resources as well as the willingness of policy makers to intervene to support specific technologies or ensure security of supply will be the key drivers of whether some incremental reforms to the current SRMC based power markets will be sufficient or whether more radical reforms to introduce hybrid power markets are required. Further work is therefore required to understand the potential barriers to the deployment of flexible resources in electricity markets and how a supportive regulatory framework can be put in place for these resources.

As regard to retail market, all markets will have to introduce reforms to drive an efficient system development given the rise of prosumers' development. The potential move away from a commodity pricing approach for electricity toward services, as well as the level of engagement of consumers will drive the speed and magnitude of the market reforms required. In this respect, further research will be required to understand how the broader changes in the way electricity is consumed and priced may affect the regulatory and market framework for renewables.

Most importantly, a comprehensive approach to market reform ensuring the consistency of wholesale and retail market arrangements with network regulation and the wider regulatory framework is key to a successful evolution of market design with high shares of VRE. Future research will therefore need to focus on the interface between wholesale and retail markets and the consistency of price signals across these different markets.

2. INTRODUCTION: CONTEXT AND METHODOLOGY

2.1. CONTEXT AND MOTIVATIONS FOR THE STUDY

The growing share of wind and solar photovoltaic energy in many countries may require reconsideration of the design of market and regulatory frameworks. In the medium to longer term, renewables are expected to represent a very significant part of the generation mix in OECD countries. Analysis from IEA¹ shows that, in many world regions, variable renewable energy sources will represent between 30 and 45% of power generation on average (see Figure 1 below), possibly reaching levels close to 100% in certain jurisdictions.

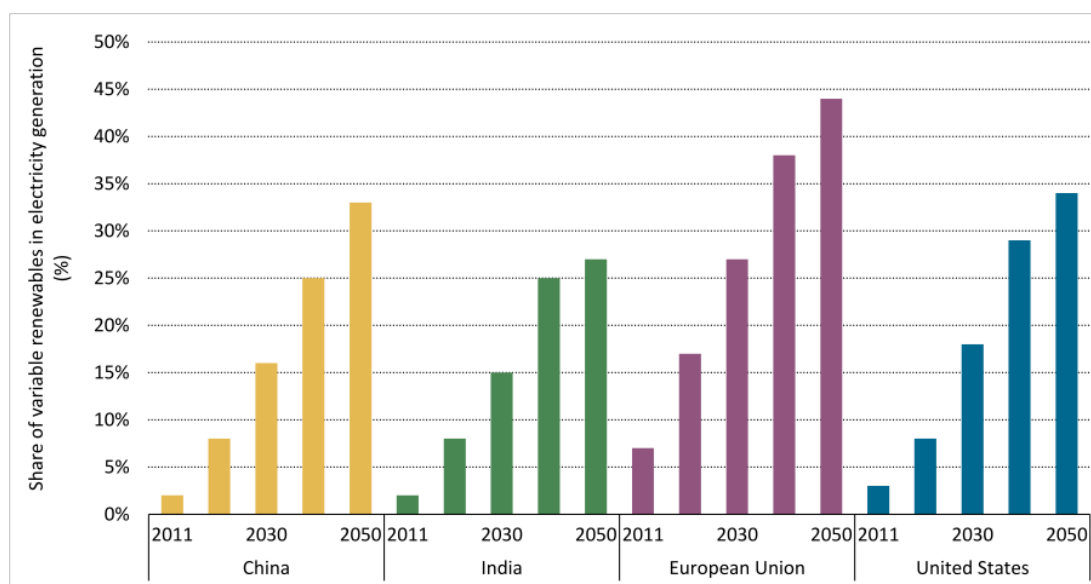

Figure 1: Share of variable renewable generation in total generation

Note: ETP 2015 provides an update on the 2DS scenarios as compared to 2014. However, it does not provide a materially different view on the share of variable renewables by 2050.

Source: IEA (2014): Energy technology perspectives, 2DS scenario

While there is a large amount of policy and academic research on integrating renewables in power markets in the short and medium term, this is almost always in a context where renewables remain a relatively modest part of the generation mix.

Existing studies mainly focus on the initial phases of the RES integration, such as the issues around the supporting RES development (design of RES support policies) and mainstreaming RES (RES integration into market end re-design of support mechanisms).

¹ IEA 2014, Energy technology perspectives

However, there has so far been little research on the design of the power market around RES in systems with a significant share of variable renewables.² As shown in Figure 2, this is the focus of the present study.

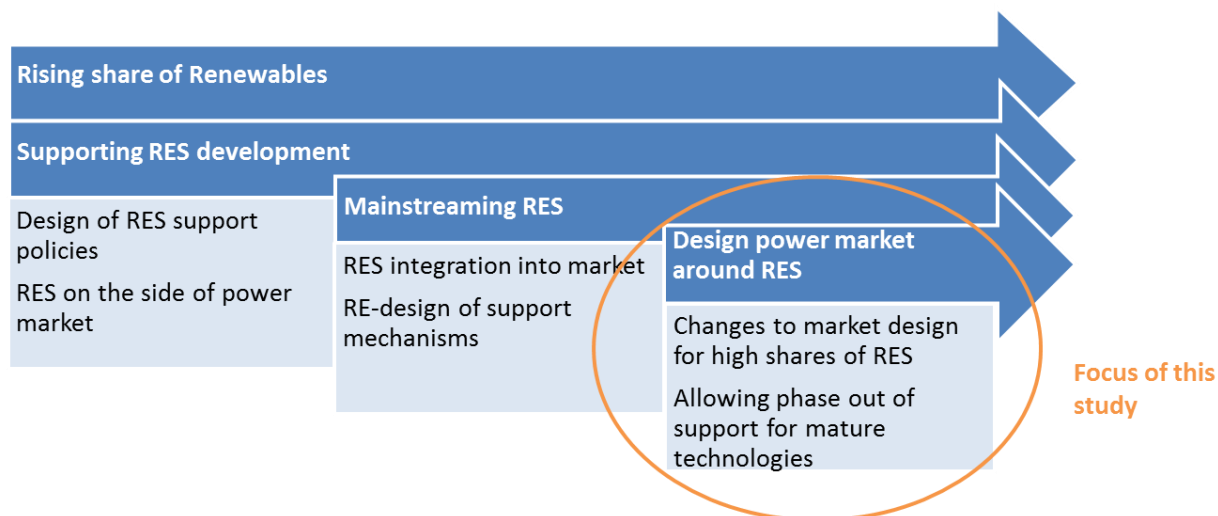

Figure 2: Phases of RES development

Source: FTI-CL Energy and NEON

Power sectors build on the backbone of the variable renewable energy would face challenges related to the properties specific to VRE, such as a cost structure dominated by fixed investment costs and variable production nature. Dealing with these challenges would require changes in the market, regulatory and policy frameworks. These challenges and the required market reforms will be different depending on the power system organisation:

- **In jurisdictions with liberalised power sector:** there is a growing concern that competitive wholesale markets co-existing with policy support for VRE deployment may not provide a level playing field and may turn out to be unsustainable in the long-term;
- **In jurisdictions with vertically integrated utilities or hybrid systems:** increasing RES capacity run by independent power producers may require revisions of the regulations defining the rules for grid access and system operation, ensuring a level playing field between the IPPs and the incumbent; and
- **In jurisdictions with active prosumer participation:** new questions emerge around the interface between retail and wholesale markets as well as the regulation of distribution system operators.

2.2. OBJECTIVES OF THE STUDY

The objective of the study is to provide policy recommendations for the direction of the reforms of the current market and regulatory frameworks in the IEA-RETD member countries and beyond, in order to accommodate high shares of renewable energy in a timely, cost-effective and secure fashion. The study aims at providing practical, relevant and implementable policy recommendations differentiated between jurisdictions with liberalised wholesale electricity markets and those without, over the time horizon of 2050. The recommendations take into account real-world constraints on policy-making.

² Examples of such studies are Neuhoff (2015), NREL (2013) and Hogan (2010)

The study builds on the pre-existing research on the design of electricity systems with high shares of variable renewables and on the previous studies of IEA-RETD and IEA (see Table 2 and Table 3 below) by:

- Focusing on the diversity of the power systems and different reforms required in different jurisdictions; and
- Applying an approach that uses the ideal market designs in the high-VRE future as a starting point.

IEA-RETD	
RES-E-NEXT (July 2013)	Assessment of issues that will shape power system evolution to high levels of variable RES-E generation. The report considers policy domains, such as securing RES-E generation, Securing Grid Infrastructure, Enhancing Flexibility and Securing Generation Adequacy
OPTIMUM (March 2014)	A generic view on challenges and key policy actions necessary to deliver the energy system of a high renewable energy world might look like in 2050, such as political buy-in, energy efficiency and mobilising investment
RE-INTEGRATION (January 2015)	Discussed criteria and factors on the relative applicability and effectiveness of options for integrating variable RE based on actual interventions to date across 9 jurisdictions
RE-PROSUMERS (June 2014)	An overview of prosumer-related aspects, focussing on residential solar PV.
RE-COM-PROSUMERS (March 2016)	Focuses on commercial prosumers and analyses various economic, behavioural, and technological drivers as well as national conditions that either support or constrain the growth of prosumers in the commercial building sector
RE-TRANSITION (Expected in 2016)	The role for RE policy after the disappearance of the cost differential between RE and conventional technologies.

Table 2: IEA-RETD studies on RES integration

Source: IEA-RETD and IEA

IEA	
GIVAR* Phase 1 - Empowering Variable Renewables, Options for Flexible Electricity Systems (2008)	Identified strategic elements to facilitate deployment of VRE
GIVAR Phase 2 - Harnessing Variable Renewables: a Guide to the Balancing Challenge (2011)	Presents a new method developed by the IEA to shed light on managing power systems with large shares of variable renewables. Written for decision-makers, it explores the twin challenges of variability and uncertainty from a technical perspective.
GIVAR Phase 3 - The Power of Transformation – Wind, Sun and The Economics of Flexible Power Systems (2014)	Provides a detailed economic assessment of the flexible resources (flexible generation, grid infrastructure, electricity storage, demand side integration) that can facilitate VRE system and market integration.
Energy technology perspectives (2015)	ETP 2015 examines innovation in the energy technology sector necessary to achieve the climate change mitigation targets. ETP 2015 identifies regulatory strategies and co-operative frameworks to advance innovation in areas like variable renewables, carbon capture and storage, and energy-intensive industrial sectors. The report provides analysis on how to meet the VRE mainstreaming challenge in different system contexts, such as a regulated system and a liberalised system.
RE-POWERING MARKETS Market design and regulation during the transition to low-carbon power systems (2016)	Can we make market design fit for purpose for decarbonisation? What changes are necessary in Short term markets, Demand response, Transmission investments, Distribution network regulation and Retail pricing?

Table 3: IEA studies on RES integration

Note: * Grid Integration of Variable Renewables

Source: IEA-RETD and IEA

2.3. STUDY APPROACH

Figure 3 gives an overview of the study approach.

The focus of this draft report is the first phase of the study. The study was organised in three tasks, as set forth in the Terms of Reference.

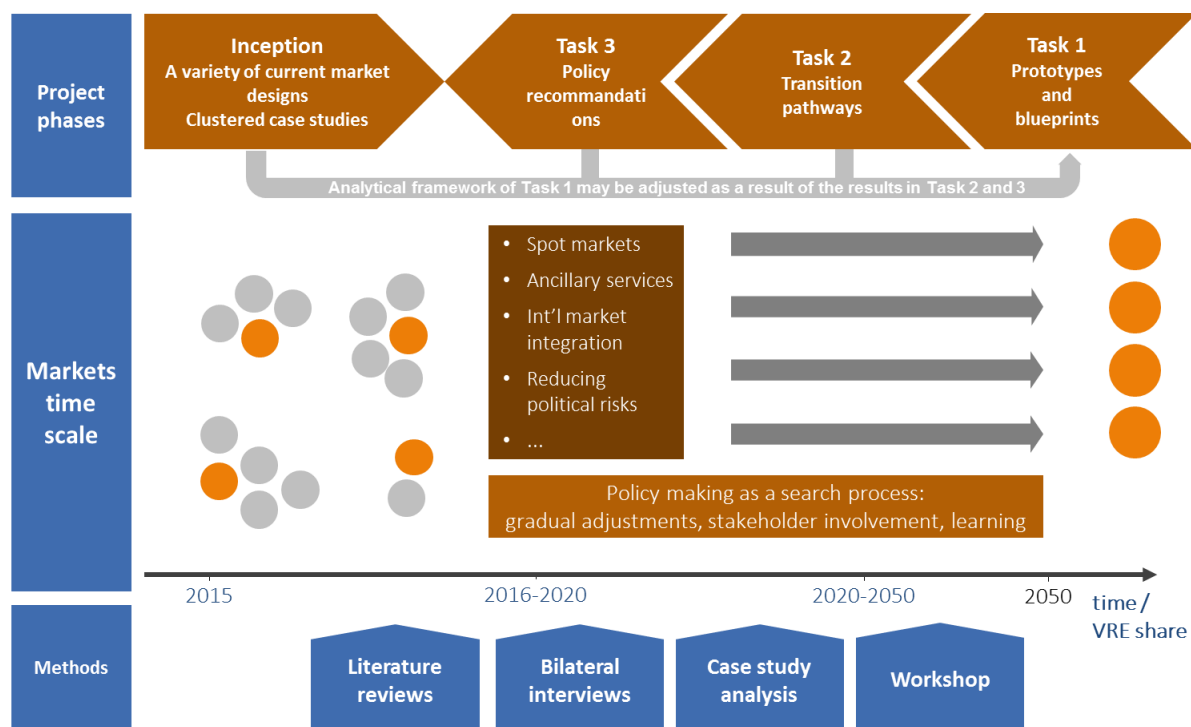

Figure 3: Overview of the proposal: from 'ideal' design to policy recommendations

The rest of this report is structured as follows:

- Section 3 presents the key challenges of high shares of VRE for the power system;
- Section 4 defines the criteria for a benchmark market design in presence of high shares of VRE;
- Sections 5 to 8 present the analyses of ideal market design and gaps between today and long-term ideal designs for each of the four prototypes of the electricity market; and
- Section 9 presents the high-level policy recommendations.

3. A THEORETICAL FRAMEWORK FOR MARKET DESIGN ASSESSMENT

3.1. INTRODUCTION

In this section we intend to achieve the following:

- Explain what “market design” comprises and why in power markets, unlike in other sectors, it is (also) a matter of public policy.
- Specify high-level and more specific evaluation criteria of power market design. This report relies on economic theory (social welfare) to derive these criteria.
- Introduce the approach we follow in this report to address the diversity of power systems and the implications for market design based on four “power system prototypes”.

3.2. WHAT IS “POWER MARKET DESIGN”?

3.2.1. A definition of electricity market design

In this report we refer to “market design” as the market, regulatory and policy frameworks in the power sector. We define market design broadly as “the set of rules that govern the interaction of economic agents in electricity generation, transmission, distribution, retailing, and trading.” Market design frames and shapes the decisions taken by market actors both in the long-term (investment, refurbishment, and retirement of capacity and infrastructure) and in the short-term (operation of the existing capacity and infrastructure).

Market design comprises, at the core, wholesale and retail market design, system services, and renewable support policies (Figure 4). These elements are embedded in a wider institutional framework that determines the role of policy and regulation, such as for instance the regulatory framework for transmission and distribution grids. These elements interact with each other and jointly determine the incentives for market actors.

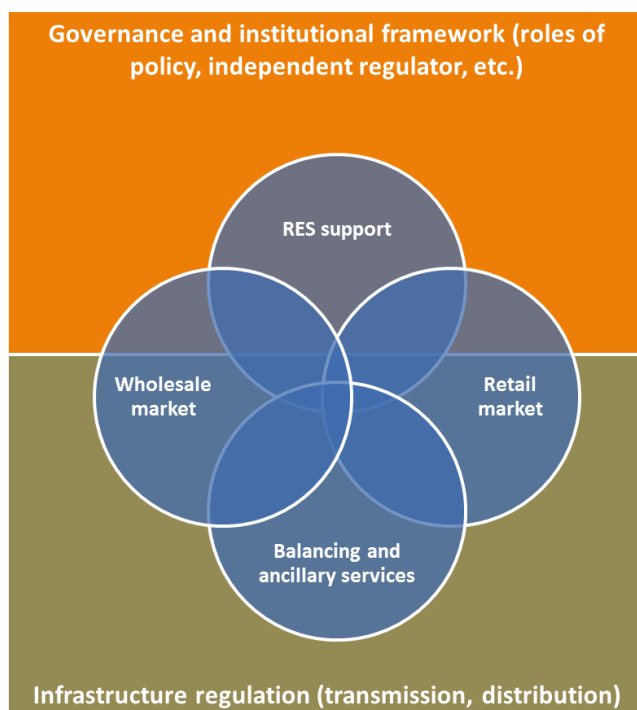

Figure 4: Market design in a wider institutional context

Source: FTI-CL Energy, Neon

In practice, market design consists of a set of rules specified by policy and regulation at multiple layers, implemented in a large number of different laws, administrative orders, market provisions, standard contracts and established norms and traditions. While the details vary from country to country, most countries regulate electricity market design in the following areas:

- **Unbundling regulation**, determining which parts of the value chain can be operated as an integrated business.
- **Grid codes**, specifying the technical properties under which power plants are connected to the grid and operated.
- **Spot market design**, determining how electricity is priced on bulk markets. In liberalised markets, this often includes specific regulation on the nature of energy markets, and power exchange operation as well as balancing rules, specifying the sanctions if contracts are not fulfilled. In markets with integrated utilities, wholesale market design includes the access and compensation rules for independent power producers and the import and export of electricity.
- **Capacity supporting mechanisms**, specifying regulation that provides additional revenues to the generating capacity through a market-based capacity mechanism, capacity payments, or capacity tenders (if any).
- **Retail market design**, determining how consumers buy electricity from retail companies or sell electricity they produce.
- **Regulation of monopolies**. In liberalised electricity markets, these are the network companies. Regulation specifies the way grid operators can charge consumers and/or producers. This often resembles regulation in other network industries such as telecommunications. In vertically integrated power sectors, regulation specifies the tariffs the public or private vertically integrated company charges to customers and its objectives for the security of supply.
- **Environmental regulation**, including support schemes for renewable energy that provide additional economic incentive for renewable-energy based power generators and emission taxes or cap and trade systems for CO₂, SO₂, or NO_x.

3.2.2. Power market design a matter of public policy

The electricity sector is different from other sectors of the economy in the way market design is established. In the vast majority of industries, the terms and conditions under which economic actors trade have emerged “bottom-up”, being established over time by market participants themselves. Market design, a term that is hardly used in other sectors, has developed over time as a result of evolving technology and is often norms and traditions rather than legislation. In contrast, in power markets governments and regulators have historically played an important role shaping market design in a “top-down” fashion, and continue to do so. This is the reason why power market design is a matter of public policy in the first place.³

There is a fundamental economic rationale why governments determine the design of power markets to a much larger degree than of most other markets: to trade electricity, all market participants need use a common infrastructure that itself is affected by trade: the electricity grid. Bilateral contracts are fulfilled by feeding in or taking out electricity into a “power pool”. Not fulfilling contracts affects power quality (voltage, frequency) and endangers system security. In other words, violation of one bilateral contract does not only hurt the contract party, but all market participants. In extreme, faulty performance of a single market actor can lead to a break-down of the power system, such that no electricity generation, consumption or trading is possible and that no contract can be fulfilled anymore. It is this externality that makes governments, regulators, and system operations determine the design of power markets, rather than let market participants determine their rules freely.

In addition to this externality of electricity trading, there are further reasons why market design is determined top-down by public policy.

- Parts of the electricity industry, notably transmission and distribution networks, are natural monopolies and other parts of the power market like ancillary services are natural monopsonies (featuring the system operator as a single buyer). Like other monopolies, electricity networks are subject to regulation and network regulation becomes part of electricity market design.
- Traditionally, a significant part of the general public sees power supply as public service. In many jurisdictions, regulators and policy makers feel they would be blamed if electricity supply was interrupted. Consequently, policy makers around the world are more concerned to ensure sufficient power supply capacity than production capacity of other sectors.

Nevertheless, public policy is not the only force that shapes market design of the power sector. It rather has and continues to evolve as an iterative interplay between the bottom-up actions of market participants and the top-down regulation of public policy.

3.2.3. The different time frames associated with electricity market design

The power market is characterised by decision-making on time scales of decades (investments in power plants or transmission networks) to seconds (activation of balancing reserves), as described on Figure 5 below. For the purpose of this report, we introduce two main categories, the long term investment planning several years ahead, and the short term operation decisions.

³ As Wolak (2000) writes, “the market structure and rules governing the operation of the electricity industries in these countries are not the direct result of independent actions by market participants-generators, retailers, and customers. Consequently, it is perhaps a misnomer to call these trading arrangements markets, because most markets or exchanges arise

Several years in advance from real time, network operators and power generators need to take investment decisions based on the future expectations of market revenues. This implies that there is a strong interaction between the decisions taken at the long-term and the short-term time operation of the system as investment signals originate in real time market signals associated with system operation. Indeed, operational decisions regarding unit commitment and dispatch, reserve procurement and activation, and congestion management which are classified as short-term determine not only market prices in the short term, but also revenues for the different assets.

It is therefore critical to conceive market design as a sequence of interlinked modules, in which the consistency between the different modules and the ability of price signals to feed through across different times frames is critical in order to provide adequate investment and operation incentives.

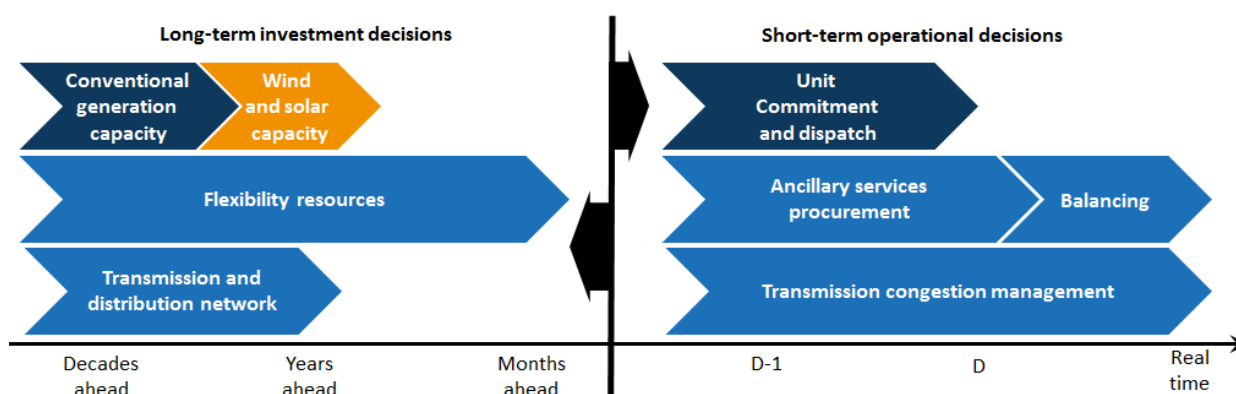

Figure 5: Elements of the electricity market, regulatory and policy framework

Source: FTI-CL Energy, Neon

3.2.4. Market design as a coordination and risk allocation mechanism

At a higher level, market design can be considered as a mechanism for coordination and risk allocation between different economic agents and the government, both in the short-term and long-term. **Power prices can be seen as a decentralised coordination mechanism between market participants**, distinguishing the liberalised markets and vertically integrated power systems:

- In the short term, power prices can be seen as a decentralised coordination mechanism for market participants in a liberalised market to arrive at an efficient dispatch of all generation units based on their variable costs. An alternative centralised mechanism used in the context of vertically integrated utilities or a central dispatcher is to have access of all units' variable costs in the system and centrally dispatch them.
- In the long term, power prices in a liberalised wholesale market can signal the need for investment or retirement, as high prices will trigger new entry, whilst low prices will lead the least profitable units to be decommissioned. An alternative centralised mechanism used in the context of vertically integrated utilities is a centralised system planner, which internalises the investment decisions through planning procedures encompassing generation and transmission expansion planning.

Figure 6 below provides an overview of the positioning of main high-level market design options on a two-dimensional matrix, depending on the decentralisation of the short term dispatch and long term investment decisions.

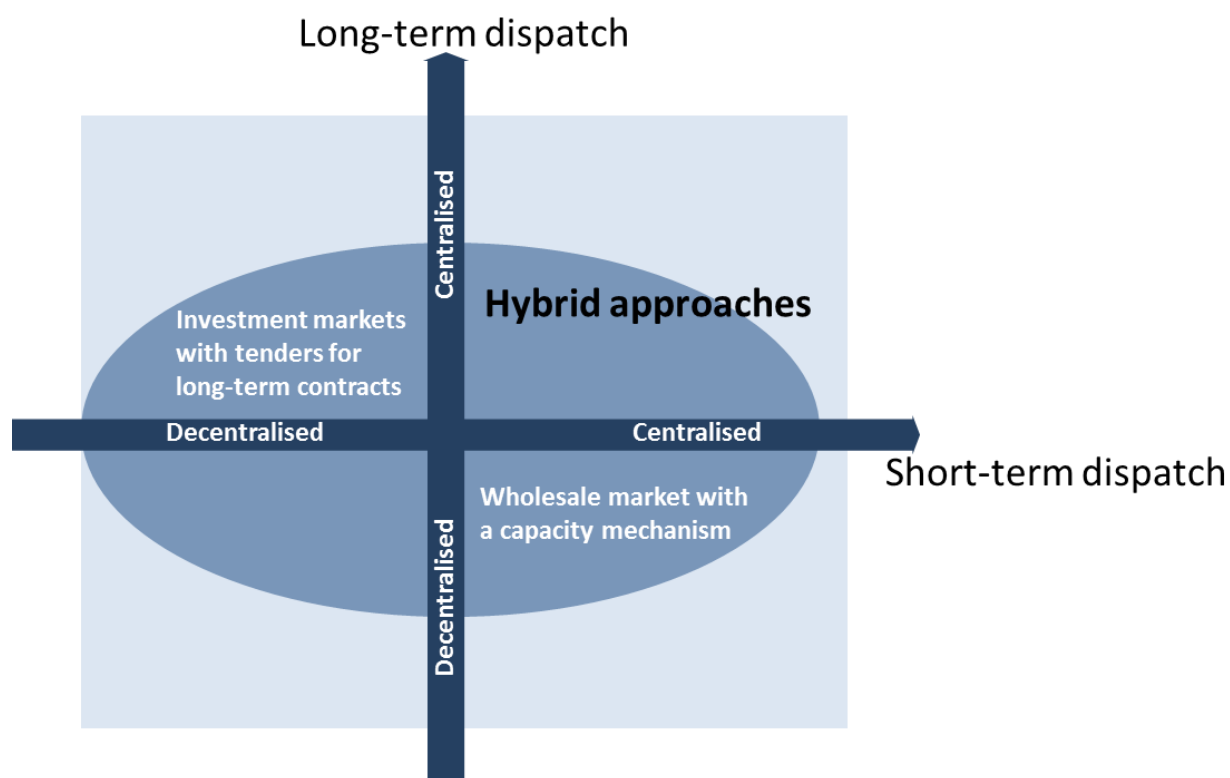

Figure 6: Decentralisation of decisions and high level market design options

Source: FTI-CL Energy and NEON

The growth of decentralised generation and emergence of active prosumers (i.e. generators located with consumers) raises an overarching issue, **namely the interaction between the retail and wholesale market price signals**. In fully competitive retail markets, prosumers actively manage their consumption in response to price signals and self-produce part or all of their needs. At the other extreme, in the case of a regulated consumer franchise, consumers' interactions with the market are limited.

Vertical integration represents a historical approach for the electricity industry, where **coordination of both the short term dispatch and long term investment are internalised in one entity through planning procedures**. Risks are automatically transferred to consumers, which can lead to inefficiencies, as it is not straightforward to provide proper incentives to investors and operators to minimise costs.

In contrast, **liberalised markets rely on wholesale market prices to coordinate different market players' actions, both in the short and long term**. Power prices provide scarcity remuneration covering part or the fixed costs and signal the need for investment or plant retirement. Similarly, decisions on the location of new generation investment and merchant transmission lines is driven by expected price differentials between system nodes. Most real-world power markets feature elements of both regimes.

Moreover, twenty-five years after the start of power market liberalisation, most markets are still 'hybrids' with some form of regulatory intervention and role for the state in either planning or capacity procurement. **Hybrid markets comprise some form of public intervention and/or central coordination or risk transfer mechanism**. These centralised coordination mechanisms can be targeted by security of supply, determination of the generation mix and/or the development of transmission networks. The level of intervention can take various forms, from heavily regulated markets to near-to 'pure markets' with a range of approaches to allocation of risk.

The decision over the risk-allocation structure can be informed by economic theory which states that risk should be allocated to the parties best able to manage them. There are five types of risk associated with power generation investments, and for each there is a most-suitable participant who should assume the risk:

- **Planning and licensing risk.** This refers to uncertainties and inconsistencies with energy policy as well as potentially complex procedures with risk of long delays. There is a role for policy makers to ensure a predictable and credible energy policy with streamlined planning and licensing procedures.
- **Construction risk.** This is concerned with whether the plant can be built to time and cost. This risk should be managed by the investor or privately passed on to contractors.
- **Operational risk.** Operational risk concerns whether the plant can be operated with high availability and efficiency. This should be managed by the plant operator.
- **Market risk.** This concerns whether power plant revenues can be hedged, and so the influence of short term volatile prices can be removed. To help with this risk, there is a role for policy makers to design a market that provides adequate hedging or risk transfer instruments.
- **Policy and regulatory risk.** This concerns the effect of interventions to support specific fuel or technology types, and the risk of infrastructure coordination issues. Policy makers need to assess the impact of their interventions, and make sure that the policy framework provides visibility to market participants.

3.3. CRITERIA FOR A BENCHMARK ‘IDEAL’ MARKET DESIGN

Different market players, such as generators, system operators, project developers, retail companies, and consumers, may apply different criteria to evaluate the electricity market and policy design. Governments too may evaluate power market design according to a wide range of policy objectives, such as: minimise the costs of electricity supply; support or expand certain generation technologies; reduce greenhouse gas emission; achieve industrial policy targets; maintain profitability of the industry; support decentralised generation or democratise electricity production. IEA-RETD (2016) emphasises that

“the actual design of the enabling framework depends on a wide range of factors, including the overarching policy objectives (e.g., RE targets, carbon targets) as well as the national circumstances (e.g., existing interconnections with neighbouring countries, political preferences, etc.)”

In the present study, we aim at identifying a benchmark ‘ideal’ market design for a power system with high shares of VRE. Given our current state of knowledge and understanding, the benchmark design represents an “ideal”. We apply an economic welfare approach. According to this approach, markets are designed well if they maximise the total economic welfare in the power sector (i.e. the benefits extracted by customers from the consumption of electricity at the resulting price and the profits of the power companies). The ultimate goal of total welfare maximisation has to be subject to a number of constraints, such as the policy objectives (decarbonisation and security of supply), operational constraints, and the linkages with a broader energy system (e.g. heat, transport).

Technically speaking, a benchmark design provides incentives that lead to statically and dynamically efficient resource allocation. We translate this very abstract objective of the economic welfare and its constraints into more specific criteria in two steps:

- we start with five high-level criteria;
- we then translate each of them into specific criteria addressing the challenges presented by the high shares of VRE.

Figure 7 summarises the welfare-economic framework, high-level and specific criteria.

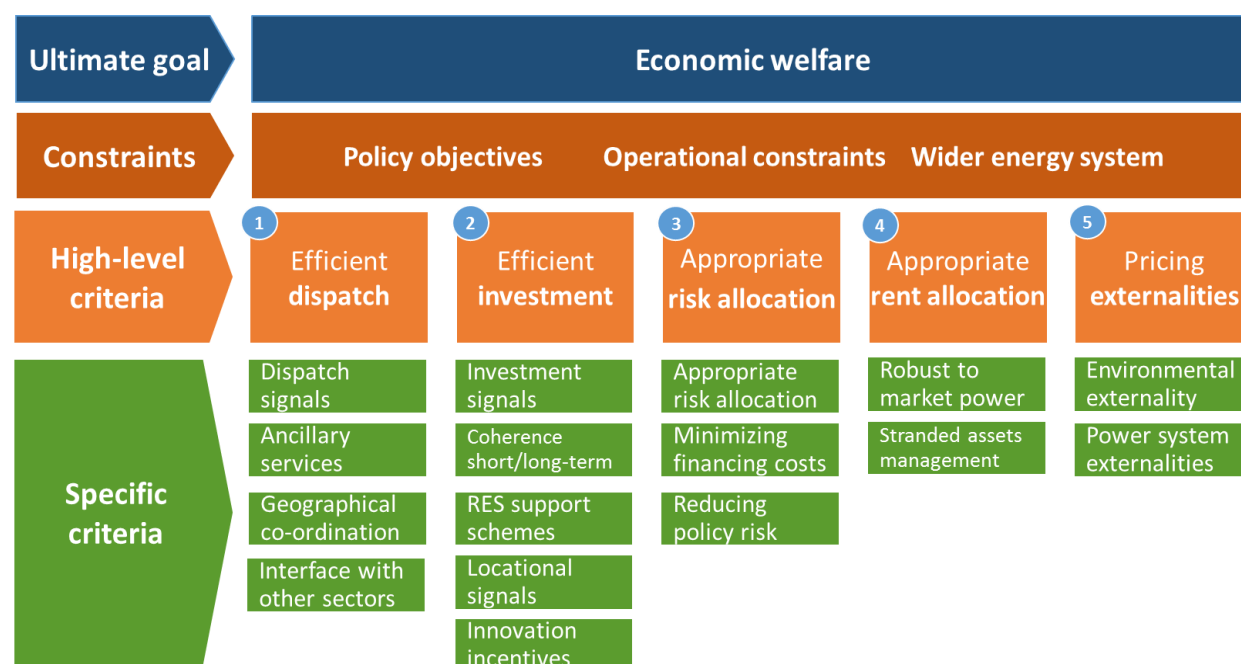

Figure 7: High-level and specific criteria for a benchmark market design

Source: FTI-CL Energy, NEON

3.3.1. High level criteria for the benchmark market design

Five criteria define a good market design and policy framework for the electricity sector:

- **Efficient operation** (dispatch) of existing assets in the short-run (generation, loads, flexibility resources). Specifically, no resource should be used if another resource could provide the same service at lower economic cost.
- **Efficient investments** in new assets in the long-term (generation conventional and RES capacity, networks, demand response, and other flexibility resources). Specifically, the market design should incentivise the right (cost-efficient) amount, the right type and the right location of assets. The market design should not induce investment that are not good from the broad social welfare perspective (e.g. too much inflexible base load plants vs. flexibility resources) as well as local scarcity.
- **Appropriate allocation of market, project and political risks** between generators investing in conventional and renewable generators, customers, other market players, and the government. Specifically, creating political (regulatory) risk increases the cost of capital for investments, making power provision unnecessarily expensive. On the other hand, market design arrangements that reduce exposure of investors to market risks or protect them from the risks can lead to inefficient overinvestment.
- **Efficient long-term rent allocation.** Market design should not create welfare transfers between different market players that are unsustainable in the long term, e.g. between producers and customers or between owners of different production technologies. For example, market design should be robust to potential gaming or strategic behaviour that may create transfers from customers to generators (abuse of market power). In addition, market arrangements should ensure a sustainable transition and avoid the creation of stranded assets.

- **Internalization of externalities.** This holds for environmental externalities including carbon emissions as well as power system externalities such as security of supply. For instance, such internalisation should induce generators to account for the social costs associated with emissions from fossil fuel plants in the operation and investment decisions. The costs to the system associated with the specificities of each generation technology (e.g. balancing costs associated with variable generation) should be reflected decisions taken by operators. In fact, as we have argued above, these externalities are the fundamental reason why market design is a matter of public policy at all.

Trade-offs and inter-dependencies between these five criteria are frequent and policy makers need to strike a balance.

3.4. DIVERSITY OF POWER SYSTEMS AND THE IMPLICATIONS FOR MARKET DESIGN

Power systems and power markets around the world are very divers. To be able to conduct meaningful analysis while deriving conclusions that are applicable to a broader set of countries, we identify model, or “prototype” power systems. Prototypes are not real-world power markets, but rather stylized concepts that we use to discuss a specific aspect of market design.

In this section we identify a set of power system prototypes that are representative of the diversity of power systems around the world. For each of these prototype power systems we identify the key challenges related to the market design in the transition toward a system with high shares of VRE. These challenges may be more difficult to meet for some power system prototypes than others. We then identify the benchmark responses to these challenges separately for each prototype.

3.4.1. The diversity of power systems and the challenges of high VRE shares

A market design that meets the criteria described above can be regarded as benchmark. However, some criteria are economically more relevant in some power systems than in others. Moreover, some of these criteria need to be traded off against each other. For example, efforts to reduce rents, such as technology-differentiated support schemes, often reduce the efficiency of such policies and increase the danger of rent-seeking. These trade-offs can be harder to resolve in some power systems than in others. In the following subsection, we discuss which criteria are especially relevant, and hence challenging, in different power system prototypes.

The challenges presented by the high shares of VRE may differ depending on the power system characteristics. Assuming that a number of power system characteristics are deemed to remain in the long term, the market design evolution necessary to integrate high shares of RES may be different for each of them.

The dimensions of power system characteristics relevant to this report comprise the following:

- Degree of unbundling and market liberalization; and
- Physical characteristics of the system.

We discuss the specific issues associated with these characteristics in turn.

3.4.2. Degree of unbundling and market liberalisation

This dimension determines the extent to which a number of interactions can be internalised within the vertically integrated utility or whether explicit market rules should be devised for these interactions between unbundled market participants.

The electricity industry can be organised in different ways, which could involve a range of interactions between public policy, regulatory bodies, and public or private companies. Historically, vertically integrated public or private monopolies have been the dominant industry structure. In the 1980s, the drive for liberalization of network industries around the world led a number of countries to introduce competition in generation and sometimes supply of electricity.

Currently a range of industry structures co-exist around the world, with liberalised power markets in most OECD countries, and a range of approaches ranging from regulated vertically integrated monopolies to a variety of hybrid models with third party investment in generation

A key difference across these industry structures is the role of the market or regulatory processes in driving investment and operations decisions for generators, and thereby the amount of risk they are subject to. For example, in the energy-only market an investor assumes the market risk of their investment, while a regulated vertically integrated utility passes the investment risk directly to customers via the regulated tariffs. Intermediate hybrid systems featuring single buyers for capacity, long-term capacity contracts and capacity markets present intermediate situations in terms of risk sharing between the generator and the customer.

3.4.3. Physical characteristics of the system

Several physical characteristics of power systems determine the necessary evolution of the market design to adapt to high shares of VRE:

- **Share of distributed resources.** A high share of existing distributed and variable renewable energy resources may more urgently require market design elements that remunerate flexibility adequately and take into account the impact of these resources on the security of supply.
- **Specific geographic constraints.** In some countries natural barriers exist to the deployment of physical transmission lines such as mountains or lakes, which make the planning and operation of the power system more challenging. Such constraints make some aspects of market design particularly important, such as locational signals to provide incentives for plant and transmission lines to be built in places which are the most efficient for the system.
- **Available 'embedded' flexibility.** The more flexibility there is a priori in the power system currently, the easier the transition to a power system with high shares of renewables. The most important sources of power system flexibility are: reservoir hydro power, demand-side response (DSR)/demand-side management (DSM), interconnection with neighbouring power systems and electricity storage, e.g. pumped storage or batteries.

3.4.4. Power system prototypes considered

Real-world market and policy design is diverse, complex, multi-level and path-dependent. To address this diversity in a transparent way, we study a small number of power system prototypes. Each real-world market represents a combination of these prototypes to a different degree. We select the prototypes in such a way that allows us to focus on specific aspects of market design.

As discussed earlier in this section, a useful approach to frame the analysis and identify relevant power system prototypes is to think of alternative market designs in terms of coordination and risk allocation mechanisms for the industry agents both in the short-term (operation of the existing capacity and infrastructure) and in the long-term (investment, refurbishment, and retirement of capacity and infrastructure).

The four power system prototypes that we selected differ in the degree of decentralisation of the decision-making, i.e. in the type of decisions that are made in a decentralised manner, based on the wholesale or retail market signals and the decisions that are made based on a separate coordination mechanism (based on some form of central planning):

- **Energy-only.** The energy-only prototype refers to a market where generating capacity investments and short term operations are mostly driven by market signals in the energy and ancillary services markets with little regulatory or policy intervention.
- **Vertically integrated.** This prototype refers to markets where both the short-term and the long-term decisions are centralised by the incumbent vertically integrated utility.
- **Hybrid.** In the hybrid prototype, although dispatch decisions remain based on wholesale power prices, generator investment decisions are supplemented by additional risk transfer or coordination mechanisms induced by the policy maker.
- **Prosumer.** This prototype refers to a power system in which a significant share of generators is located with consumers that are connected to the low- or medium-voltage distribution grids and are small in size. The wholesale market can be either organised as an energy-only market, as a vertically integrated utility, or as a hybrid market. In this sense, prosumer markets are cross-cutting.

These prototypes are illustrated in Table 4. The countries listed as examples show important characteristics of the respective prototype. However, the prototype is an analytical concept and does not correspond to any real-world market in all its details.

Prototype	Energy-only	Vertically integrated	Hybrid	Prosumer
Dispatch decisions	Decentralised through wholesale market prices	Centralised based on costs and other drivers	Decentralised through wholesale market prices	Decentralised through retail market prices
Investment generation	Decentralised through wholesale market prices	Centralised based on planning	Centralised based on planning and/or risk sharing mechanism	Decentralised through retail market prices
Examples	Texas, Australia, Europe	South Africa, US	Brazil, UK	Germany, Australia, California

Table 4: Power system prototypes depending on the degree of decision centralisation

Source: FTIC-CL and NEON

In the Sections 5 to 8 we discuss these prototypes one by one, presenting in more detail the real-life examples of the prototypes, the benchmark ‘ideal’ design of the critical elements of each prototype’s market design, gaps between the current practice and the benchmark market designs and the steps necessary to close these gaps.

4. KEY CHALLENGES TO POWER SYSTEM WITH HIGH SHARES OF VRE

4.1. INTRODUCTION

In this section we identify the challenges associated with amounts of VRE in a power system that represent close to 100% annual electricity consumption. These issues also arise at VRE market shares lower than 100%, but become more pressing with increasing penetration. The issues associated with significant shares of variable renewables generation can be grouped into two sets of questions, depending on the time horizon considered:

- In the short term: How to ensure efficient power system operations with significant shares of variable renewables?
- In the longer term: How to ensure efficient power system investment and development?

Table 5 below lists more specific questions within each of the two sets.

Short term: How to ensure efficient power system operations?	Long term: How to ensure efficient power system investment and development?
<ul style="list-style-type: none"> • What properties do power markets need to support integration of variable renewables? • What support policies minimise interferences with the market? • What market design and regulations are required to deal with intermittency and maintain system stability? • How can incentives be designed to maximise system operating flexibility? 	<ul style="list-style-type: none"> • How to facilitate financing for capital intensive technologies? • How to ensure efficient transfer and hedging mechanisms? • How to coordinate and provide efficient investment signals across decentralised and centralised generation, and network expansion?

Table 5: Issues associated with significant shares of VRE

Source: FTI-CL Energy and NEON

4.2. CHALLENGES OF HIGH SHARES OF VRE TO POWER SYSTEMS AND MARKET DESIGN

Several critical characteristics of wind and solar energy create a number of changes in the power systems when these energy sources are present at a large scale. The characteristics have been well documented in the literature. In this report we focus in particular in this report on the following:

- Capital intensity and low short-run marginal cost;
- Limited predictability and variability; and
- Decentralised and scattered generation.

The challenges posed by the high shares of VRE in power systems translate to challenges to power market design (Table 6). Some of these are mentioned as key challenges for policy approaches related to RES development in the RES-E-NEXT study (IEA-RETD 2013).

VRE property	Power system challenges	Market design challenges
Capital intensity	Changing cost structure Optimal generation mix shifts	Fixed cost recovery, cost of capital Credible investment incentives
Limited predictability and variability	Short-term dispatch coordination Time horizon of power system operations shortens Assurance of system stability	Price volatility and uncertainty Spot market design Design of ancillary services
Decentralised and scattered generation	Transmission and distribution grid planning and operation	Geographic coordination between generation and grids Prosumers: retail pricing and metering rules

Table 6: How challenges to power systems turn into challenges to market design

Source: FTI-CL Energy, NEON

Below we address these properties one by one.

4.2.1. Capital intensity and low marginal cost

VRE energy is capital intensive in the sense that almost 100% of its costs is represented by the cost of capital and only a small share of the cost is represented by variable cost of generation. This is, to some extent, also true for other low-carbon generation technologies, as shown in Figure 8.

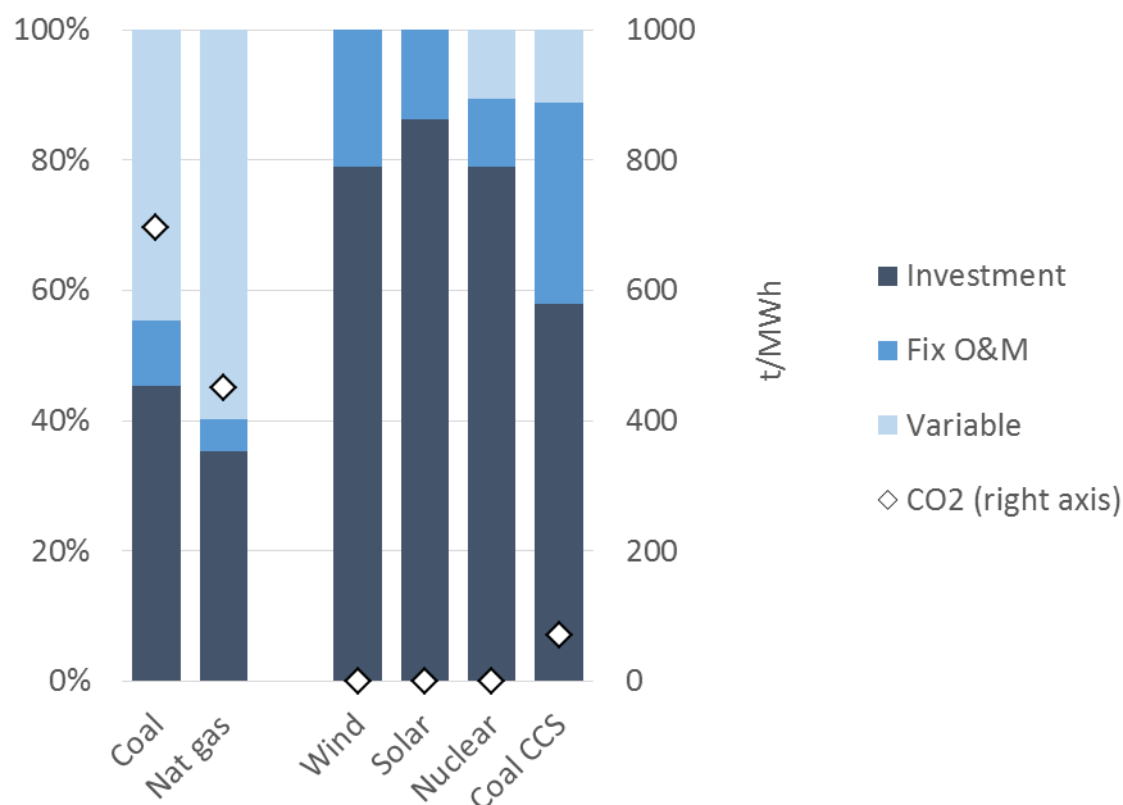

Figure 8: The share of investment cost in levelised generation costs

Source: Hirth & Steckel (submitted)

Networks and flexibility resources necessary to ensure smooth operation of a power system based on VRE, are similarly capital intensive. With increasing share of VRE, the electricity sector transforms from an industry with significant variable cost of energy generation to an industry with low variable cost and high capital cost (a transition from the “OPEX world” to a “CAPEX world”).⁴ This raises two interrelated issues, which materialise differently in liberalised power markets and in other types of industry organisation:

- Investment cost recovery with volatile revenues, and the various ways in which revenue security can help attract financing investment in renewable and supporting generating technologies at reasonable cost.
- The cost of capital (expected rate of return of investors), as reducing the cost of capital through an efficient risk allocation can significantly reduce total costs for capital intensive assets.

Cost recovery

Competitive wholesale power markets are based on the fundamental principles of the peak load pricing theory (Boiteux 1949, Crew et al. 1995). During times of moderate demand, market participants bid their short run marginal costs (SRMC), but during scarcity they are able to bid higher prices (“scarcity prices”). Fixed cost are recovered through: i) inframarginal rents as technologies with higher SRMC clear the market and set the power price, and ii) scarcity rents when the market is tight and prices go beyond the SRMC of the technology clearing the market.

This theory has been developed with variable electricity demand in mind. Adding variable generation to meet variable demand does not fundamentally change anything, in theory. Marginal cost pricing can still work with a part of the generation mix having zero or very low SRMCs. However, prices are becoming more volatile as the renewable technologies with low SRMC clear the market increasingly frequently. This increases generators’ revenue uncertainty.

Increasing price volatility and uncertainty may create challenges for the cost recovery of generating assets through market prices. In practice, a number of market failures in current electricity markets often undermine fixed cost recovery and create “missing money”. The risk is that increased power price volatility driven by high shares of renewables would magnify the impact of current power market imperfections and make fixed cost recovery even more challenging.

The cost of a marginal MWh of electricity produced in a system with high shares of VRE would likely become quite volatile. This is all the more so in a system that has little flexibility provided by storage resources as well as interconnection with other areas that have such resources. In a less flexible system, the system marginal cost may quite often be determined by the VRE resources at very low level with rather isolated spikes in the system marginal cost representing the cost of scarcity during the peak demand and low renewable production.

In a competitive system, the volatile system marginal cost would determine a volatile price and associated revenue uncertainty. The shift towards a low-marginal cost system creates significant challenges for investors in the generating capacity, both VRE and flexible, that has increasingly a CAPEX- and not OPEX-

⁴ It is certainly the case that high-VRE power systems are more capital-intensive than fossil fuel based power systems. However, also traditional power systems are fairly CAPEX-intensive when compared to other sectors.

dominated cost structure. A particular issue is the impact of the increased market risk exposure on risk adverse investors, and the associated increase in the cost of financing.

The increased price volatility does not necessarily mean that the existing model of investment cost recovery based on scarcity pricing would need to be changed. Such models exist in other industries with high CAPEX and low OPEX that also face significant demand volatility (e.g. airlines and hotels).

However, to accommodate high shares of VRE, special attention should be given to solving some of the current market imperfections which undermine fixed cost recovery, as well as to foster the development of risk hedging instruments. An efficient allocation of risks will be critical in systems with high shares of VRE to ensure that capital intensive investments can be financed with reasonable hurdle rates.

In addition, the market design will need to foster the development of flexibility sources for the system, including DSR, interconnection, and storage.

Cost of capital

In liberalised markets, one key issue is whether, after the RES support schemes are phased out, there would be a viable investment framework and, in particular, if renewables investors will be ready to take merchant risk without requiring overly high hurdle rates. This in turn depends on the development of liquid markets and hedging instruments. It also depends on the risk aversion of investors.

The market and regulatory arrangements have a key role to play in driving the type and structure of financing arrangements supporting investment in power generation. In this sense, the reliance on volatile power prices based on SRMC may lead to high costs of financing if risk adverse investors ask for high hurdle rates in order to compensate for market risk exposure.

It is important to point out the critical importance of how investors perceive the different types of risks and how these risks can be managed and/or transferred through contractual arrangements. One overarching objective of the different market designs envisaged in this report is therefore to explore the ways in which the risks can be allocated so as to reduce the cost of capital and attract financial investors.

It is worth clarifying that risks never disappear, but allocating them to parties best able to bear them can reduce the cost of handling risk. In financial terms, this means that the cost of financing and thereby the total cost of a project can be reduced through an appropriate market and regulation framework which allocates risks efficiently.

The impact of flexibility

The share of flexible resources in a power system is a key element to determine to what extent the change in the cost structure toward capital intensive low variable cost generation will require a fundamental change in market design. In order to provide some intuition for this, we consider two types of power systems:

- A power system where low marginal cost technologies supply 100% of demand without much flexible resources in the system;
- A power system where some technologies with low marginal costs as well as flexibility resources prevail.

The case of a power system without much flexibility

In the first case, the marginal cost of electricity supply – the change in system costs as demand is increased incrementally – is almost always very low, possibly close to zero. A power system with a VRE share close to 100% may be characterised by both offshore and onshore wind as well as solar capacity, and the average energy produced by these resources is close to meeting all of the demand.

In such systems, the short-run marginal cost structure is very different from the short-run cost in the current existing systems. Variable renewable resources generally have high capital costs but a very low marginal cost. Figure 9 shows the forecasted levelised costs and short-run marginal costs in 2050. Although the total levelised cost of renewable technologies is comparable to that of the supporting flexible technologies (natural gas (with and without CCS) and biomass), the graph suggests that the marginal cost may become close to zero for most of the supply merit order. The short-run marginal cost will occasionally be set by the flexible thermal generation or by the level at which the demand-side resources are ready to reduce demand.

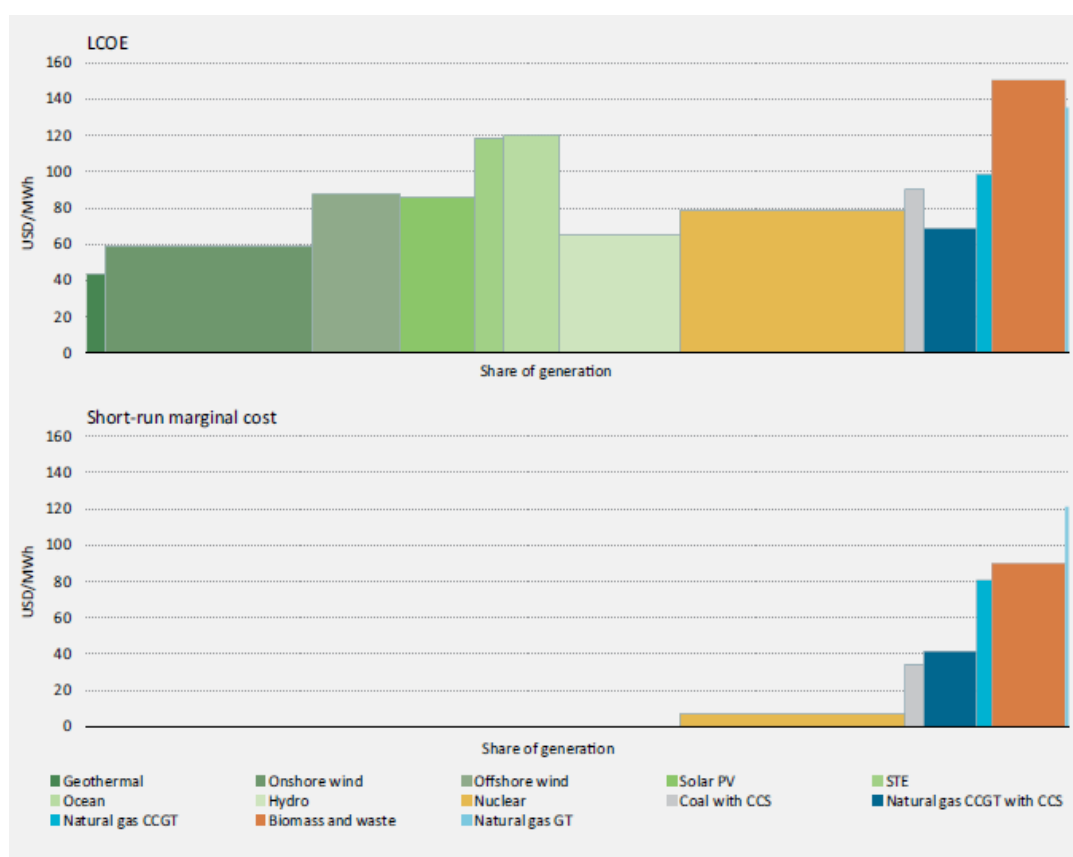

Figure 9: European Union long-run levelised costs and short-run marginal costs in the 2DS, 2050

Note: 2DS refers to a scenario aiming at limiting climate change to a global temperature rise of 2°C

Source: IEA 2015, Energy Technology Perspectives

A large number of periods may be expected when demand can be entirely satisfied from low-marginal cost technologies. In that case, in a competitive market, the electricity price would be close to zero for a large proportion of hours, if storage and export possibilities are absent.

In such a system with an energy-only market, theory suggests power prices would increase during an instance of peak demand. However, it seems unrealistic that a positive price in a few hours of the year can provide a price signal that is reliable enough to serve as an investment incentive, even assuming that risk hedging contracts are in place. In addition, the risk associated with such a pricing dynamic would lead risk adverse investors to require high hurdle rates and increase the total system costs.

Moreover, if all generators have similar low marginal costs, prices (or any other cost-based mechanism) cannot be used to coordinate generators' operational decisions. **In such a world, a fundamentally different market design model would likely be needed both for the short term dispatch and for the long term investment incentives, and the introduction of some additional coordination and risk sharing mechanisms would be needed.**

The case of a power system with significant flexibility

However, our theoretical example with 100% low marginal cost technologies seems unrealistic. In reality, even in a system with very high shares of RES, some generation technologies will prevail that have positive marginal costs, such as biomass plants with or without carbon capture and storage (CCS), or some natural gas-fired CCS plants. Such plants would tend to set market prices at levels above the marginal cost of renewables. Moreover, electricity demand is likely to become more price-responsive in the future, such that prices are set by the demand side during peak events. In addition, the development of electricity storage will help to smooth electricity prices and “transmit” spike prices to time periods where prices would otherwise be zero. Finally, interconnection to neighbouring power systems will allow exporting the cheap energy towards more expensive areas most of the time, with the effect of increasing the price in the exporting areas, thus “importing” positive prices.

The presence of system storage may have an important impact on the distribution of the cost of the last MWh of energy needed to meet the demand (system marginal cost) and therefore the price. System storage may take the form of reservoir hydro, pumped storage, distributed storage, e.g. from electric vehicles, as well as transmission interconnection, allowing storage in the neighbouring areas. Storage can materially smooth the price variation, reducing the price during the peak hours and increasing it during the off-peak hours. Even relatively small volumes of storage would be sufficient to materially smooth the price volatility induced by VRE. Take the example of Norway currently, where nearly 100% of electricity is supplied by zero marginal-cost hydroelectricity, but prices remain positive because of price-elastic demand, interconnections and the opportunity cost of scarce hydro storage.

Under the IEA 2°C Scenario (2DS) presented in ETP 2014, electricity is almost fully decarbonised by 2050 in Europe and about two thirds of electricity is generated by technologies with low marginal cost: nuclear (21.5%), wind (31%) and solar PV (11%). Electricity price modelled by IEA in this scenario exhibits high variability with zero and low levels in only about one third of the time (Figure 10).

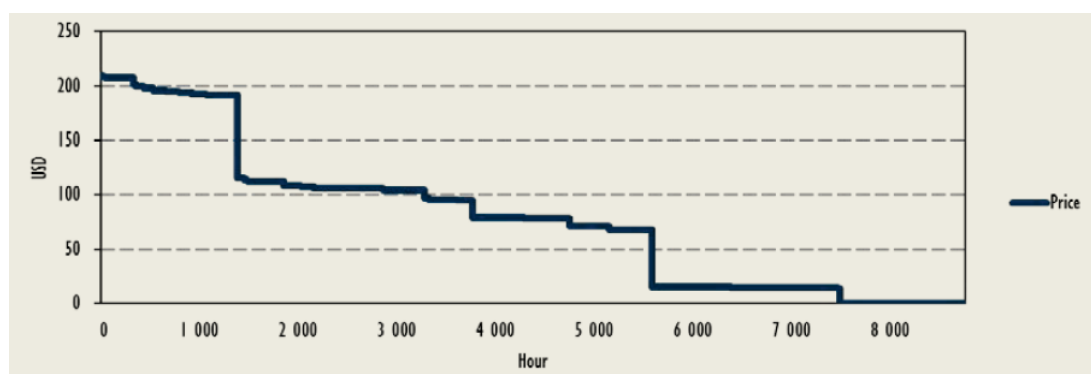

Figure 10: Modelled price duration curve in ETP 2DS scenario, 2050

Note: 2DS refers to a scenario aiming at limiting climate change to a global temperature rise of 2°C

Source: IEA 2015 RE-POWERING MARKETS

In such a power system with significant flexibility, pricing and market design does not need to be fundamentally different from today. However, some aspects of market design would need to be adjusted.

4.2.2. Variability and limited predictability

Variability and limited predictability of VRE has an impact on a number of aspects of the power system operation:

- Optimal generation mix;
- Time horizon for the power system operations; and
- Assurance of the system stability.

Optimal generation mix

The optimal thermal power plant mix in systems with high shares of VRE is very different from that in systems without wind and solar power. Traditionally, a high share of all electricity has been generated by power plants that run continuously, so-called “baseload” plants. In a power system with a predominant share of wind and solar generation in yearly energy terms, fewer baseload plants are needed (Hirth et al. 2015). Instead, thermal power plants are needed to operate only part of the time, in the so-called “mid-load” and “peaking” mode. Generally, a system with high shares of VRE would rely more on flexible resources: interconnection, demand-side management (DSM) and storage.

With increased variability of net load, the economic value of electricity becomes more volatile, which is expressed in short term prices. In the systems with high shares of VRE, conventional plants tend to earn a larger share of their costs in fewer hours of the year, associated with a lower rate utilisation. Flexibility provided by conventional plants, as well as other flexible resources, to back-up VRE production may need to be remunerated by some form of a flexibility service.

More volatile prices and a larger role of very high price spikes is not only a challenge for generating companies and other market players, but also for market power monitoring and mitigation policies. During scarcity events, abusing market power is particularly easy for suppliers, and identifying market power abuse is particular difficult for regulators. This requires appropriate training, tools, and data for regulators.

The challenge presented by high VRE shares to the market design due to the VRE’s limited predictability and variability is referred to in the RES-E-NEXT study (IEA-RETD 2013) as the challenge of “Short-Term

Security Of Supply: Enhancing System Flexibility”. This refers to the need of the systems with high VRE shares for more power-system flexibility to maintain system balance.

Time horizon for the power system operations

Historically, power systems were optimised around a day-ahead scheduling of power plants. This was the case in both liberalised markets, in which the key market is the day-ahead, and in integrated power systems in which the vertically integrated power company schedules plant dispatch based on the anticipated load and plant availability.

The variability and uncertainty of wind and solar power is likely to shift this day-ahead operational timeframe towards higher temporal granularity and towards shorter gate-closure. This tendency is enforced by reduced transaction costs as information technology penetrates power markets and power system operation.

Nonetheless, the transmission and distribution system operators need to control the system in real time. This creates a question as to where to draw the line between markets and the system operators’ control.

As mentioned above, in the short term, power prices act as a coordination mechanism between market participants to yield efficient dispatch of generation units based on their variable costs and merit order. The efficient short-term dispatch resulting from the bid-based short-term markets is often considered as one of the largest benefits of the liberalised markets.

In a system with little flexibility, high volume of VRE capacity and energy would often determine system marginal cost at zero level. In this case the efficiency of decentralised dispatch coordination through prices may be reduced and it could be reasonable to consider introducing centralisation elements in the dispatch decisions. This would effectively mean a transition towards a vertically integrated power system.

By spot markets we refer to the markets where electricity is traded shortly before delivery and that serve as a reference for physical dispatch of plants. Spot markets often comprise day-ahead and intraday markets. These markets may also include markets for other short-run products that could be suited to hedge the specific risks of VRE (e.g. markets for operating reserves).

The shift of the operational timeframes from day-ahead to higher temporal granularity and towards shorter gate-closure induced by variability and uncertainty of wind and solar power will require changes in the spot market design necessary to accommodate faster trading and/or dispatch decisions made on a larger scale, and closer to real-time.

Assurance of system stability

In real time, electricity generation, consumption, and transmission will always deviate from schedules planned in advance, e.g. day-ahead: equipment can fail, and consumers can demand more or less power than expected, for example because of an unpredicted temperature shift. Deviation from the supply-demand balance need to be stabilised at short time scales to avoid frequency deviations and damages to power plants.

A system with high share of VRE is subject to larger deviations from schedules predicted in advance, as compared to hydro or fossil-fuelled power plants. Short-term power system operation would have to evolve to cope with surprises induced by the high volumes of VRE. For example, a system with high shares of VRE could require flexible generators to be even more flexible, calling for the ability to ramp up and

down faster to follow the variation of the demand net of the renewable generation. For the same reasons, a system with high shares of VRE would require more storage.

A system with high share of VRE featuring larger deviations from schedules predicted in advance would require different system operation and hence different amounts and probably also types of ancillary services. Short-term power system operation would have to evolve to cope with surprises induced by the high volumes of VRE:

- Provision of ancillary services would need to account for a higher demand for these services induced by VRE. The services should be adjusted to reflect the properties of VRE. For example, balancing power should be sized dynamically to be cost-efficient.
- Provision of ancillary services would need to be able to accommodate a broad range of technologies and market players providing them, including VRE themselves. For example, balancing power auctions need to be designed such that VRE generators can participate.
- High volume of VRE may induce the need for new products and services, e.g. providing system inertia, which is often not remunerated today.⁵

4.2.3. Decentralised and scattered generation

Historically, power industry developed around large scale centralised power plants, justified by increasing returns to scale. Transmission system expansion was relatively simple in the sense that it was largely driven by the need to connect the locations of the main plants and load consumption centres. A power system with high shares of VRE would have very different drivers for development of both the transmission and the distribution networks, as compared to the conventional power system.

In a high-VRE power system, a significant part of generation is likely to be decentralised and far from load centres. This implies a number of challenges for market design:

- Need for coordination between (transmission and distribution) grid expansion and generation expansion;
- Need for a framework to deal with prosumers that produce and consume electricity at one site;
- Need to adapt to the possible evolution of retail pricing approaches

Coordination of VRE with the transmission network

Good sites for wind and solar power are characterised by high availability of the primary resource (much solar irradiation, high wind speeds), low land prices, and little effects on competing types of land use (housing, tourism, conservation). Such sites tend to be far from densely populated load centres.

VRE-rich power systems tend to require a change in the historical approach to the transmission network expansion, where network has been built between central generation and consumption centres. Coordination is not only needed on the investment time scale, but also on the operational time scale. The need for market signals for locational scarcity and line congestion becomes more important.

⁵ Thermal and hydro power plants produce electricity in a synchronous generator linked electromechanically to the grid. Wind power and solar PV do not. Synchronous generation provides inertia (“rotating masses”) that ease the impact of very short-term supply-demand imbalances. Traditionally, inertia was a by-product of power generation and its supply is not compensated financially in most countries. There are ways to provide inertia without conventional plants, e.g. through batteries, condensers, flywheels or “synthetic inertia” from wind turbines. To provide investment incentives into these technologies, inertia is likely to need to be priced.

The challenge presented by high VRE shares to the market design due to the VRE's decentralised and scattered nature are referred to in the RES-E-NEXT study (IEA-RETD 2013) as the challenge of securing grid infrastructure.

Coordination of VRE with the distribution network

Renewables, especially solar PV, are highly modular. This makes it possible to generate electricity in a decentralised manner in a cost-efficient way. This has major consequences for the power system under high VRE shares:

- More plants are connected to distribution grids, requiring better coordination between expansion of the distribution grid and generation location decisions;
- Market participation becomes scattered, requiring market rules to accommodate a large number of small players and/or allow aggregators to operate and
- If small-scale investments are made consumer's site, the relevant price signal for investment and operation is the retail electricity tariffs, rather than wholesale electricity prices.

Prosumers generate and consume electricity on a single site. To the extent locally generated electricity replaces grid-delivered power, it is valued at the retail price, rather than the wholesale price. Hence the retail prices and its components, such as network tariffs and taxes, becomes the incentive for investment and dispatch, rather than the wholesale price. If prosumers play an important role (or are meant to play such a role), the retail price changes its role and needs to be seen as a price signal, rather than a mere cost recovery mechanism.

Another challenge of prosumers is the erosion of tax and system operator income. This problem may arise because base for grid fees, taxes, and levies is often calculated on grid-delivered electricity consumption (cent per kWh). With rising auto-generation, the same revenue has to be collected from a smaller base, increasing the rate of fees and taxes. Higher prices, in turn, further increase the incentives to auto-generate. This self-enforcing feedback mechanism has been described as "de-solidarization" or "death spiral" (Grattan Institute 2015).

A final challenge to power market design connected to decentralised generation is how to organise access to wholesale markets in a cost-effective manner, and how to organise balancing responsibility for small actors.

Need to adapt to the possible evolution of retail pricing approaches

Today, electricity is priced to customers as a commodity. Other commodities, notably telecommunication services, show examples of a radical retail transformation from commodity to more service-oriented pricing. Nowadays, phone companies generally do not sell minutes of connections, but instead a set of services like availability, connectivity, permanent internet access and more specialised application-based services.

The transition to a power sector with a high share of VRE and low variable cost could be taking place within the context of a broader transformation reducing the importance of energy commodity prices and transforming the retail energy supply into a service-oriented good, rather than a commodity. Further, technology companies like Google or Tesla might be able to bundle electricity consumption with other goods and harvest cross-selling potential (including data collection), while at the same time attracting consumer interest in energy-related smart home applications. These developments could have a dramatic

impact on the way the retail electricity market is designed, in the sense that the retail electricity price would no longer drive consumers' decisions.

However, the possible move toward service-oriented pricing on the retail side of the electricity industry does not mean that the commodity price would not exist as it would likely remain an important driver of operation and investment decisions at a more upstream level. For example, retail aggregators and retail suppliers would likely still be trading electricity at the wholesale level with reference to a wholesale commodity price. They would then re-package the product into the service-oriented good for the retail customers only.

The interface between retail and wholesale prices could evolve depending on the pricing approach for electricity in retail market. Depending on the approach, retail prices may not include all taxes / levies supporting clean technologies, and/or network charges. This would have important implications for the market design in order to induce an efficient system development and operation.

4.3. SPECIFIC CRITERIA FOR A BENCHMARK MARKET DESIGN WITH HIGH SHARES OF VRE

The five high-level criteria mentioned in Section 3 above can be translated into a longer list of specific criteria for power systems with high shares of VRE. These criteria are universal in the sense that they are independent from existing power system properties and the market structure. In the following subsection we will apply them to the market design prototypes introduced above. These specific criteria for a benchmark market design with high shares of VRE are:

1. *Efficient operation*

- **(Day-ahead and intra-day) dispatch signals** should accurately reflect the physical conditions, constraints, and scarcity of the power system to allow valuing electricity produced by various plants and flexibility (of generation capacity, demand response, and other flexibility resources). In case of high shares of VRE, these signals should be sufficiently close to real time to account for the latest changes in wind and solar forecasts.
- **Ancillary services** should satisfy system security requirements while allowing a cost-efficient provision by all technologies that are able to provide them. Remuneration should reflect both the marginal costs of providing these services, and the marginal benefits to the power system. The costs of ancillary services should be allocated to all market participants according to the “causer pays” principle, including loads and VRE generators, designed in a way to not introduce excessive risks on market participants. In high-VRE shares systems product definitions, procurement rules, and pricing should allow conventional and VRE generators as well as loads and other flexibility sources to participate and compete fairly on the basis of their costs. Historically, ancillary services such as balancing power were sized statically such as once in a year (sometimes they vary by time of the day). In high-VRE power systems they should be sized dynamically, such that, for example, most balancing power is available when the wind and solar situation is most uncertain such as during arrival of a storm front.
- **Co-ordination mechanisms** should coordinate the dispatch of geographically distributed assets (flexible and variable, centralised and distributed resources), taking into account grid constraints and the nature of power flow, including the grid constraints across power systems, providing for the integration of the flexibility over larger geographic regions.
- **Consistent interface with other energy sectors.** The electricity sector should represent a consistent interface with other energy sectors, such as heat and transport. Absence of inefficient barriers between energy sectors can be ensured by ensuring a consistent end-user pricing across sectors, including taxes and infrastructure charging. For example, differential taxation of electricity relative to other energy

carriers could hinder electrification of these sectors, and might prevent flexibility provision of such consumers.

2. Efficient investments

- **Investment signals** should incentivise the amount of and the type of generation capacity, storage, demand response, and other flexibility resources that allow maximise the social welfare in the long run. In particular, the variability of wind and solar PV generation requires sufficient flexible resources to reliably balance supply and demand at all times and in order to integrate variable renewable energy (VRE) cost-effectively. As large-scale VRE deployment tends to increase the variability and uncertainty of residual load (load net of VRE generation), and shifts the optimal thermal capacity mix from base load towards peak load technologies, specific attention needs to be given to investment signals for peaking plants and flexibility resources.
- **Coherence between short-term and long-term price signals** is required such that long-run investment signals incentives induce the amount and type of assets that are required according to short-run signals mentioned above. In essence, this means that any explicit incentive for investments need to carry all the information embedded in short-term signals.
- **Renewable supporting schemes** should support investments in the renewable energy in the amount necessary for meeting policy targets that transmit short-term price signals to investors. Despite support schemes, renewable generators should be subject to short-term price signals (turning plants off if prices become very negative), be balancing responsible (trying to forecast precisely), and be subject to the same congestion management rules as other generators (aka dispatchable).
- **Locational signals** are to coordinate investments in generation, load, and storage assets with investments in transmission and distribution grid infrastructure, e.g. network infrastructure access and grid fees for independent and distributed generation sources, for conventional and for VRE generators, and for flexibility resources.
- **Innovation** across power systems, technology and business models are essential to ensure the development of power systems with high shares of VRE. Market, policy and regulatory frameworks must encourage and guide such innovations.

3. Appropriate allocation of market, project and political risks

- **Risk allocation should be appropriate.** Sound economic theory suggests that risks should be allocated to the parties best able to manage them. Project risks should be borne by project developers, market risks should be borne by producers and consumers. Power system policies should not undermine the confidence in the basic market and regulatory paradigms by increasing the policy risks. Risk allocation has always mattered, but it matters even more in power systems with high shares of VRE, because wind and solar power are more capital intensive than fossil power plants, and flexibility resources also tend to be investment intensive. Risk can be re-allocated across market participants through hedging forward contracts both mandatory and entered in either on the voluntary basis.
- **Minimizing the costs of financing can have a significant effect** for capital intensive generation technologies, such as the renewable technologies, that incur the great majority of costs up-front. Such low-cost financing is needed to provide sufficient visibility on future revenues to unlock large-scale deployment. Unlocking low-cost finance is key to reduce the costs of high-VRE power systems.

4. Efficient long-term rent allocation

- **Market design should be robust to market power.** Due to the specific nature of electricity which cannot be stored economically, producers on a specific node of the network can have significant market power.

Special care needs to be given to ensuring that the market rules are robust to market power. A range of preventive remedies and ex post controls are typically in place in liberalised power markets. .

- **Stranded assets management schemes** should allow smooth transformation and decarbonization of the power system without placing undue regulatory risk on the existing assets. Investors might be compensated for losses directly caused by unforeseeable policy decisions, but should not be compensated for bad investment decisions. Any compensation scheme requires careful design and needs to be based on firm principles in order to avoid rent-seeking behaviour.

5. Internalization of externalities

- **Environmental externalities are priced.** This holds for the climate externality (greenhouse gas emissions) as much as for health externalities (pollutants) and other externalities (radioactive waste and nuclear plant decommissioning). The price can be explicit, as in emission taxing or cap and trade systems, or implicit, as under command and control regulation. To be efficient, the price should be the same for all facilities and market players, and should reflect the true cost of the externality to society. Renewable support schemes that do not explicitly price the externalities should be designed to minimise the distortion impact on market design and be gradually phased out.
- **Power system externalities are priced.** All actors on the power market use the same underlying infrastructure, and deviating from agreed contracts can lead to the collapse of this infrastructure. Markets need to be designed to reflect these costs. One example is imbalance pricing, the price actors have to pay for supply or consuming more or less electricity than scheduled. The imbalance price should reflect the probability a schedule deviation leads to the system black-out.

These criteria are consistent with those developed for example in the RES-E-NEXT study (IEA-RETD 2013) as to the principles for Integrated Power System Policy. In particular, RES-E-NEXT considers the principles of Rediscovering Coordination, Bolstering Confidence in Regulatory and Market Paradigms and Guiding Innovations. As opposed to the present study, RES-E-NEXT is oriented on the public policy rather than market design.

5. ENERGY-ONLY MARKET

5.1. INTRODUCTION

The energy-only prototype refers to a market where generating capacity investments and short term operations are entirely driven by market signals in the energy and ancillary services markets. In the energy-only prototype, both short-term generator operating decisions and long-term investment decisions are based on the wholesale market prices with no other regulatory or policy intervention. Merchant investment in transmission is coordinated thorough wholesale power prices. Central planning however is possible in the regulated transmission investment and potentially short-term transmission management.

The major challenges are investment incentives, driven either by expectations of future short-term prices alone or in conjunction with (structured or freely emerging) financial markets. Examples of jurisdictions that possess important characteristics of the energy-only prototype are Texas, Australia and a number of European countries.⁶

5.1.1. Case study: energy-only market in Texas (ERCOT)

The decentralisation of North American regulation has led to a variety of market structures among US states and Canadian provinces. Texas is one of the few examples of a power system featuring an energy-only market with scarcity pricing in North America.

Over the last decade, Texas has experienced a significant development of variable renewable resources, driven by favourable wind resources and federal and state support schemes. The installed capacity of wind power in 2013 was 12,355 MW (about 10% of total installed capacity). This is double the volume of 2008. Currently, wind production in Texas is the highest of among the U.S. states. While Texas has one of the largest solar potentials in the country, deployment is currently limited.⁷ In 2013, the installed PV capacity amounted to 216 MW.⁸

The development of wind in Texas was largely due to the state's Renewable Portfolio Standard. After fast early deployment in Western Texas, the state's transmission grid came under severe stress and significant wind power needed to be curtailed. In 2005, Texas introduced so-called Competitive Renewable Energy Zones (CREZ) with a view to achieving the objectives of expanding wind power generation. Within these zones, transmission investment plans are developed to facilitate the integration of renewable energy generation. These plans involve simplification of the procedures for building new transmission lines, along with a commitment to pass on the investment costs to consumers if the lines are not sufficiently used.

⁶ Even though a number of ancillary services feature capacity remuneration, such remuneration is typically provided for *spare* generating capacity. Such spare capacity has string arbitrage with energy production, unlike installed capacity remuneration in the hybrid prototype.

⁷ http://www.nrel.gov/gis/re_potential.html

⁸ Sherwood (2012)

5.1.2. Case study: energy-only market in Australia (NEM)

The NEM (National Electricity Market) operates in the East and South-East of Australia, supplying about 80% of the electricity consumption of the country. NEM serves a peak demand of about 35 GW (2010-2011) and energy consumption of 190 TWh (2012-2013).

Variable renewables represent a share of about 7% of consumption.⁹ In the NEM Wind generation is concentrated in the South Australian market zone, where the wind generation represent around 25% of generation.¹⁰ Australia has experienced a boom of small-scale solar PV installations of households.

NEM is an energy-only market with no explicit support for capacity.¹¹ Transmission congestion is considered in the form of bidding areas, between which limited transmission capacity is available. The NEM operates a variety of system services.¹²

5.1.3. Case study: European energy only markets

Most power markets in Europe share many characteristics of the energy-only market prototype, as there is no specific mechanism to put a value on generating capacity when the system becomes tight (with the exception of Spain, Portugal, Italy, Greece and Ireland which have some form of capacity payment, as well as the UK and France who have recently introduced capacity mechanisms¹³).

Most European markets feature a day-ahead and an intra-day spot market. Trading intervals vary between 15 minutes and one hour. In contrast to the “central-dispatch” market of Texas and NEM, European markets are “self-dispatched”. Power exchanges offer a platform for trading but this trading remains voluntary and bilateral (“over-the-counter”) trading is possible as well. System Operators are not involved in the wholesale trading. Ancillary services are procured separately under a range of different auction and direct procurement rules.¹⁴ Transmission constraints are only taken into account at national borders, except in Norway, Sweden, Denmark, and Italy, where two to five bidding zones are used. Recently, the way transmission constraints are incorporated in the price determination has become significantly more sophisticated with the introduction of implicit market coupling and flow-based market coupling.

5.2. CRITICAL ELEMENTS OF THE BENCHMARK MARKET DESIGN

In the energy-only market, generators make investment decisions based on the revenues they expect to receive in the markets for energy and ancillary services.¹⁵

⁹ <http://www.iea.org/statistics/relatedsurveys/monthlyelectricitysurvey/>

¹⁰ Rautkivi and Arima (2014).

¹¹ Riesz and MacGill (2013).

¹² Riesz et al (2015)

¹³ France is currently in the process of approval of the capacity mechanism by the European Commission.

¹⁴ Hirth and Ziegenhagen (2015), Rebours et al. (2007)

¹⁵ Although in many jurisdictions generators currently have problems recovering fixed costs of generation investment through the energy and ancillary services markets, it is not clear whether this is related to the choice of the power market paradigm or other external factors (e.g. recession and slow demand growth, renewable support schemes, etc.). A number of jurisdictions are minded to maintaining the energy-only market paradigm (e.g. European Nordic region, Texas, Australia).

In this power system prototype, the most critical element of the regulatory, policy and market framework is the design of these short-term markets. Although such markets also exist in the hybrid or prosumer market power system prototypes, the design of the short-term market is not as critical as it is in the energy-only prototype, where it has to meet a number of specific market design criteria.

Other critical elements may include locational signals necessary for coordination between the generation, transmission and distribution networks and improvement of the investor confidence through forward hedging and broader market design and regulatory elements.

This suggests the following broad elements of market design that are critical in the energy-only market prototype facing the challenges presented by VRE:

- **Design of spot and ancillary services markets.** The short-term markets value electricity and flexibility produced by various plants and DSR in a time frame which is sufficiently close to real-time to account for changes in the wind and solar forecasts. High variability and low predictability of VRE would make the short-term markets increasingly important.
- **Locational price signals.** Increasing distance between generation and consumption resulting from the increased VRE shares would require better coordination between the network operation and the dispatch of the VRE and flexible generation in the short term, and the network and generation investment in the longer term.
- **Development of hedging products.** Increased capital intensity and price variability induced by high VRE shares would increase the need for investors to be able to lock-in the variable market revenues in advance.

Table 7 below summarises the critical elements of the market design in an energy-only prototype.

Element of market design	Challenge presented by VRE
Design of spot and ancillary services markets	Shift of the operational timeframe to real-time Increased capital intensity and price variability New requirements for AS products, and new constraints to provide them
Locational price signals	Increasing geographical distance between generation and consumption
Development of hedging products	Classical product definitions loose relevance (e.g., peak / off-peak) Increased capital intensity and price variability

Table 7: Critical elements of the market design in a energy-only market prototype

Source: FTI-CL Energy and NEON

In the remaining subsections, we discuss each of the critical market design elements of the energy-only market prototype. We identify the 'ideal' benchmark market design, identifying the gaps with the currently existing markets and providing high level policy recommendations for the evolution of the market design element.

5.3. DESIGN OF THE ENERGY AND ANCILLARY SERVICES MARKETS

5.3.1. Benchmark market design

The design of the short-term markets should be able to value electricity and flexibility produced by various plants and DSR in a time frame which is sufficiently close to real-time to account for changes in the wind

and solar forecasts. The markets for electricity operated close to real-time are reflective of the real-time market conditions.

The short-term markets should ensure that, in periods of scarcity, prices are not prevented from rising to reflect the value of electricity in such conditions. Scarcity prices are crucial for the efficiency of incentives for investments. To ensure investor confidence, policies need to allow for price spikes during scarcity situations. Policies allowing price spikes during scarcity need to be effectively coordinated with the policies that are intended to limit the undue market power exercised by generators and thereby protect consumer welfare. This could be done for example by implementing targeted scarcity pricing mechanisms (see Hogan 2005, 2014), that are based on the administratively-set demand curve for operating reserves that can sets prices for both energy and reserves in periods of scarcity. IEA 2016 also suggests that “a form of regulation of scarcity prices is necessary to ensure accurate price formation during the scarcity hours,” realising that bidding high prices could be associated with certain problems.

Design of short-term energy and ancillary services markets should provide sufficient valuation for flexible resources. In combination with other regulatory and policy measures, these markets should facilitate development of DSR and storage to ensure that these resources limit price variability induced by the high shares of VRE and increase investor confidence in the energy-only prototype.

The volume requirement for ancillary services and balancing markets should be determined to satisfy the security requirement, given the high-VRE share, and should allow VRE and non-VRE generators and other flexibility resources to participate and compete for the services.

The benchmark criteria for the market design of energy and ancillary services markets can be summarised as:

- Spot price signal reflecting real-time market conditions;
- Credible scarcity pricing; and
- Efficient valuation of ancillary services and reserves.

5.3.2. Bridging the gaps

Ideally, spot and ancillary (system) service markets should be designed in such a way that prices are efficient (i.e. they reflect all underlying costs and physical constraints in the power system).

Market price signals reflecting real-time market conditions

In theory, a series of markets where electricity is traded for forward delivery from years and months-ahead to day- and hour-ahead, should reflect the expected value of electricity at the moment of delivery (in other words, in real time). However, the sequence of electricity markets across different timeframes may often be complex and intertwined, creating barriers for arbitrages along the forward curve and preventing the day-ahead and other forward prices from reflecting the expected real-time value of electricity.

In Europe, the current market framework is overly reliant on price signals derived from day-ahead markets. The day-ahead price serves as the main “spot” price reference, despite the development of the intraday trading in many countries in recent years (in Nord Pool and Germany, intraday markets are quite

liquid).¹⁶ The real-time value of electricity is typically represented by the “imbalance price” in balancing markets, which is the price paid for deviations from announced schedules. In a benchmark market design, the imbalance price should reflect the true marginal costs of system balancing and should incentivise all available flexibility resources to contribute to the system demand-supply balance.

In practice, system operators and regulators often discourage market players from responding to balancing signals. In some countries, such as Germany, such a “strategic” response is explicitly prohibited. In other markets, the imbalance prices are often designed to dissuade market participants from arbitraging between the traded markets (day-ahead and intraday) and the balancing markets. One obstacle for such arbitrage is the “dual price” imbalance price.¹⁷ Although the dual imbalance price intends to incentivise the producer to be balanced, it discourages generators from running voluntary imbalances even when such an imbalance helps the system to stay in balance overall. Other problems include punitive mark-ups, legal barriers to responding, long dispatch periods, and the fact that reserve costs are often socialised (where activation costs are distributed to balancing responsible parties).¹⁸ Barriers to such arbitrage may dampen the price signals in the spot and forward markets. Although various activities are ongoing to develop intraday trading and to remove barriers between real-time balancing markets and traded markets (migration to single price imbalance prices), this process is slow.

In contrast, many US electricity markets are closer to the benchmark market design (such as the ERCOT market in Texas). These markets feature a day-ahead and a real-time market. In these markets, the day-ahead is considered as a forward market, allowing trade in advance of real-time delivery to hedge the risks associated with the real-time market and to lock-in the revenues from the day-ahead unit commitment. Hedge efficiency is achieved through measures allowing systematic convergence between the day-ahead and real-time prices:

- **High consistency of the organisation between of the day-ahead and real-time markets.** This is achieved through having the same entity that runs both the day ahead and real time market (the Independent System Operator or ISO) and using a consistent optimisation and network model between the two timeframes;
- **Short dispatch intervals and gate-close.** American markets often feature five-minute trading intervals and are cleared shortly before real-time. This reduces the role of balancing system services and the misalignment of prices of such services and the real time market; and
- **Virtual trading.** These arrangements allow market participants to offer non-physical generation and load into the day-ahead market and settle those transactions in the real-time market. Such trades represent about 20% of the actual load in New York and help facilitate price convergence as well as adding liquidity in the day-ahead energy market, which allows financial players to participate.

Absence of barriers to arbitrage between the day-ahead and the real-time market can be evaluated by the degree to which the day-ahead price converges to the price in the real-time market over a long period of time. In a well-functioning market, participants should be able to freely arbitrage between these markets and such arbitrage would eliminate sustained price differences over the long-term (although

¹⁶ In many countries, intra-day market is organised through continuous trading and no single price for each trading interval exists.

¹⁷ Vandezande et al. (2010)

¹⁸ See Hirth and Ziegenhagen (2015)

short-term price differences are natural). Figure 11 below presents the comparison of the monthly average real-time and day-ahead prices in ERCOT in 2014.

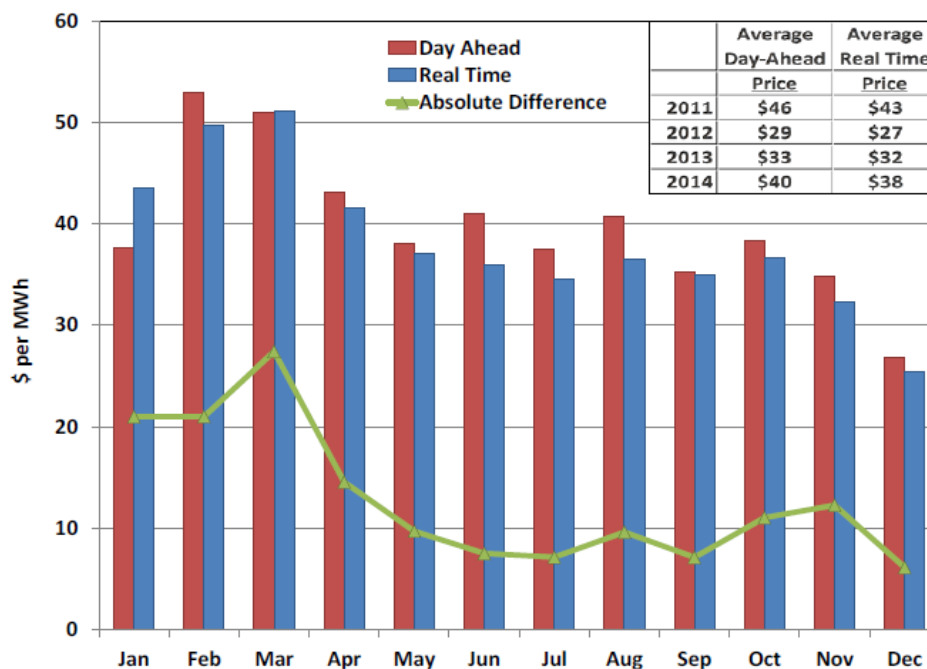

Figure 11: Day-ahead and real-time electricity prices in 2014

Source: Potomac Economics, 2015, ERCOT State of the Market Report, 2014

This analysis suggests that, although day-ahead and real-time prices follow the same trend on average, there is a consistent day-ahead premium (i.e. the day-ahead price is consistently higher than the real-time price). This premium may indicate that certain barriers still exist for arbitrages between the day-ahead and real-time markets in ERCOT.

In Australia, the NEM market design is based on a gross mandatory pool, which means that all physical energy is bought and sold through the market. The NEM is a single-platform market with only a five-minute real-time market. Unlike other markets, there is no day-ahead market, or intra-day market. Instead, market participants manage their own unit commitment with the assistance of pre-dispatch forecasts provided by the AEMO. Such a focus on the real-time naturally makes the real-time price the main spot price reference.

Credible scarcity pricing

The assumption underpinning the current market design based on energy-only markets is that power prices could climb to the value of lost load (VOLL) at times of scarcity. These price spikes set the incentive for generators to invest in peaking capacity and to recover the fixed costs of the peakers. Base-load and mid-load plants earn scarcity rents during price spike events, but recover most of their fixed costs during “normal” peak times when the market-clearing price is above their variable cost.

In Europe, the market evidence suggests that the power prices are not allowed to reach the VOLL, reducing revenue for plant operators. This is the so-called “missing money” issue, as referred to in the

academic literature.¹⁹ One cause of this problem are the operational price caps (e.g. Spain with 180€/MWh or 150€/MWh in Greece and a higher day-ahead market price cap of 3,000€/MWh in CWE),²⁰ which are still materially lower than VOLL, which, according to various estimates, reaches 10,000 to 20,000€/MWh. This also includes other measures preventing the exercise of market power to the politically unpalatable nature of very high power prices.

Moreover, the recent regulation on wholesale energy market integrity and transparency (REMIT)²¹ in Europe defines a number of trading practices that may represent normal arbitrage trades as unlawful manipulation. If the REMIT regulation prevents legitimate trades revealing the true value of electricity, this may further limit the capability of the markets to achieve high prices during scarcity periods.

Occasional price spikes occurring during shortage periods may be subject to competition investigations.²² Credible scarcity pricing requires non-distortive market power and manipulation legislation, in other words, market power monitoring that explicitly acknowledges that price spikes are a normal and legal feature of an energy-only market. In many countries, market power legislation does not reflect this fact and regulation agencies are not equipped with the necessary analytical toolkits. Regulatory agencies sometimes apply standard market power criteria to electricity markets, failing to acknowledge the fact that price spikes are consistent with competitive behaviour.

The Electricity Market in Australia (NEM) provides an example of practices close to the theoretical benchmark for scarcity pricing. First, NEM features a very high Market Price Cap (MPC) set at 12,900 AUD/MWh.²³ Second, compared with many international markets, there are relatively few restrictions placed on offers by market participants. In particular, they are permitted to offer generation at any price up to the MPC. Market participants may re-offer their energy at any time until immediately before the relevant five minute dispatch interval. Exercising transient market power during scarcity events is viewed as an important feature of the NEM design as it avoids the missing money problem.

As a result of this organisation of the energy-only market, the wholesale electricity prices in NEM are quite volatile. In particular, the South Australian market zone is the most volatile one, due to its high share of renewables. The average electricity price between July 2012 and July 2013 was around 50 AUD/MWh, but the 5 minute price hit the MPC of 12,900 AUD/MWh several times during the financial year.

¹⁹ See for instance Finon and Pignon (2008)

²⁰ The CWE power exchanges do not trade day-ahead above 3000 €/MWh, but bilateral trading at prices above this level is possible and intraday prices can reach up to 10,000 €/MWh. Likewise, balancing prices can be very high (e.g. 100,000 €/MWh in Germany)

²¹ EC (2011)

²² Examples: CRE (2008), ThinkSpain, (2015)

²³ Riesz and MacGill (2013)

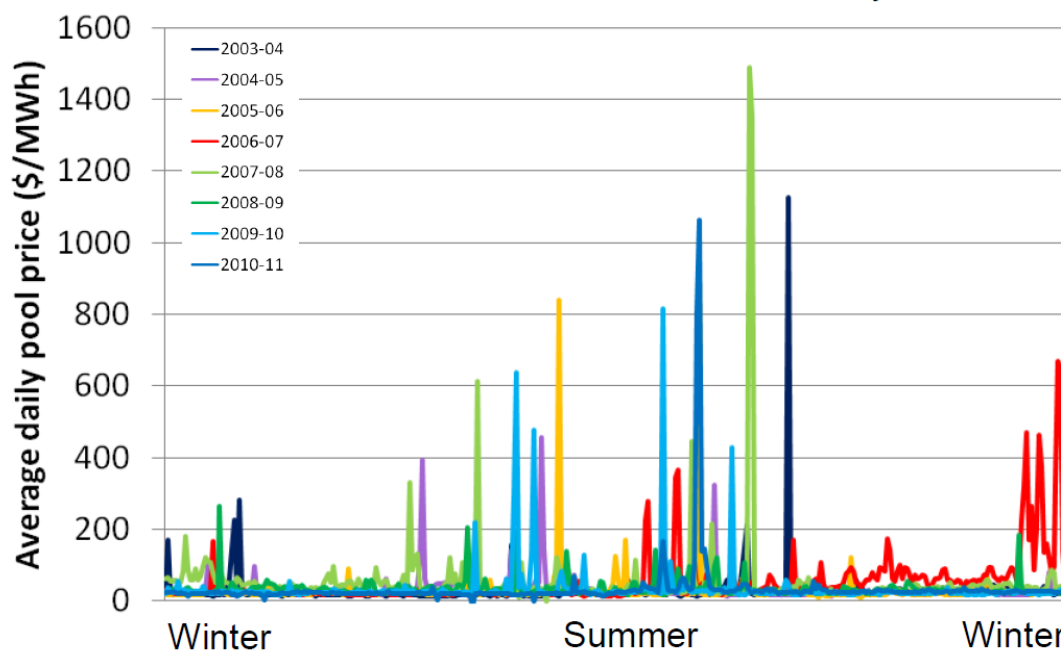

Figure 12: Average daily pool prices in NEM, 2003-2011

Source: Riesz (2013)

The volatility and the high price spikes are accepted among the market players and the consumers, as it is publicly understood that the high prices are needed to cover the capital expenses of peaking generation in order to provide flexibility to the power system.

Texas (ERCOT) also provides an interesting example of addressing the scarcity pricing issue. On the one hand, the ERCOT's dispatch software includes an automatic process of ex-ante mitigation of market power. The main focus of this process is to mitigate bids of generators that could potentially raise prices during transmission congestion when the generator's output is required to manage the congestion. According to the market monitor, this process could have resulted in overly restricted prices.²⁴

On the other hand, a special scarcity pricing mechanism is deployed that allows the energy prices to rise to a very high level in case of a shortage of short-run capacity in meeting the demand for electricity and operating reserves. This mechanism, which has been in place since 1 June 2014, is based on the Operating Reserve Demand Curve (ORDC). This mechanism calculates and adds an additional component to the real-time price, reflecting the loss of load probability (LOLP) at different levels of operating reserves multiplied by the value of lost load (VOLL). As the quantity of reserves decreases in times of scarcity, the price of reserves as well as energy would increase. Figure 13 below suggests that when available reserve capacity drops to 2,000 MW, payment for reserve capacity will rise to VOLL, or \$9,000/MWh.

²⁴ According to the ERCOT State of the Market Report (Potomac Economics 2015), the process as initially implemented would erroneously mitigate competitive generation offers. This unnecessary mitigation was addressed on June 12, 2013 with the introduction of an additional "impact" test to determine whether units are relieving or contributing to a transmission constraint and a mitigation applied only to units the relieving the constraint.

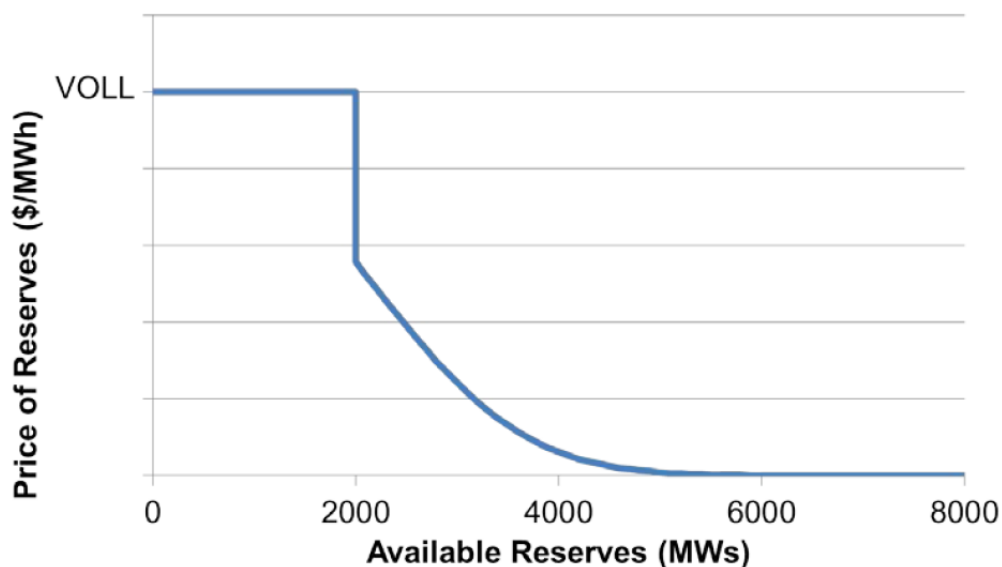

Figure 13: Operating reserve demand curve

Source: Potomac Economics (2015)

Demand-side participation

One of the key issues in many markets today is that, in the absence of active demand-side participation for load that is not metered in real time, market participants have no way to signal the value they place on power at different times. This calls into question the hypothesis that market forces determine the adequate level of installed capacity and guarantee security of supply. Various other market imperfections have also been mentioned in academic literature, including market participants' short-sightedness, risk aversion, the difficulty of hedging or transferring risks on a long term basis and needing to implement separate arrangements to guarantee security of supply.²⁵

Current market framework in Europe makes it difficult for all sources of flexibility to compete on a level playing field. In particular, demand-side response is not widely allowed to participate in balancing markets. Except for a few instances, demand-side response cannot be valued explicitly in the market.²⁶ Figure 14 shows the level of implementation of demand-side response across Europe. In a few countries, DSR is gradually allowed to participate in balancing markets and to provide reserves. They are also integrated in capacity mechanisms, which are being implemented at the moment in France, the UK and Belgium, for example.

However, there is not yet a robust and clear framework to enable DSR operators and third party aggregators to value DSR in wholesale energy markets, except in France where a new regulatory framework was established in 2013-2014.

²⁵ See e.g. De Vries (2007) or Roques (2008).

²⁶ There are some interruptible contracts in some countries but these are used only in exceptional circumstances when security of supply is at stake.

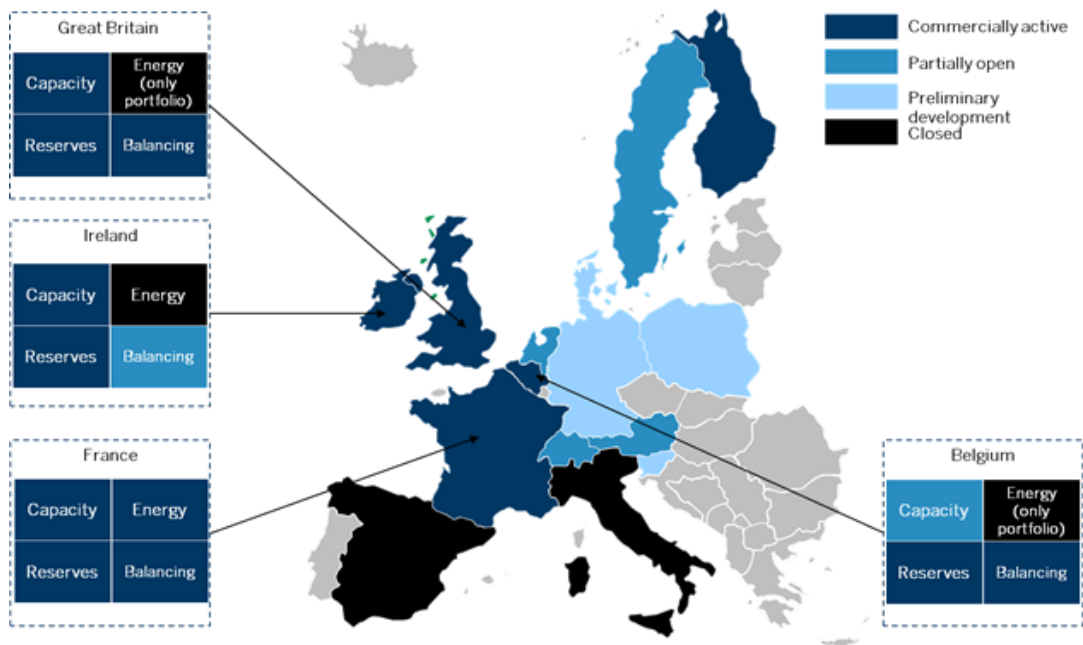

Figure 14: Evaluation of European countries market framework for demand response

Source: FTI-CL Energy (2015)

Efficient valuation of ancillary services and reserves

Efficient valuation of the flexibility service provided by fast ramping generation, storage and demand response requires not only efficient spot and real-time electricity markets, but also efficient markets for ancillary services, such as operating reserves.

In Europe, balancing reserve capacity is typically procured in advance of real time, sometimes years in advance. The lack of a short-term price signal for the reserve capacity may create a number of problems, such as an inaccurate valuation of flexibility. Absence of a short-term price signal for reserve capacity excludes the use of the scarcity pricing mechanisms, such as in ERCOT.

At the same time, the cost of providing Operating Reserves is the opportunity cost relative to the energy market. The opportunity cost varies almost as much the energy price varies as marginal plants have the lowest cost of providing Operating Reserves and plants that are in the money or out of the money have a high cost of providing Operating Reserves. The relationship between the hourly opportunity cost of providing Operating Reserves and the energy price is illustrated in Figure 15 below. The graph illustrates the relationship between the opportunity cost of providing upward reserves (left panel) and downwards reserves (right panel), depending on the spot price for various technologies.

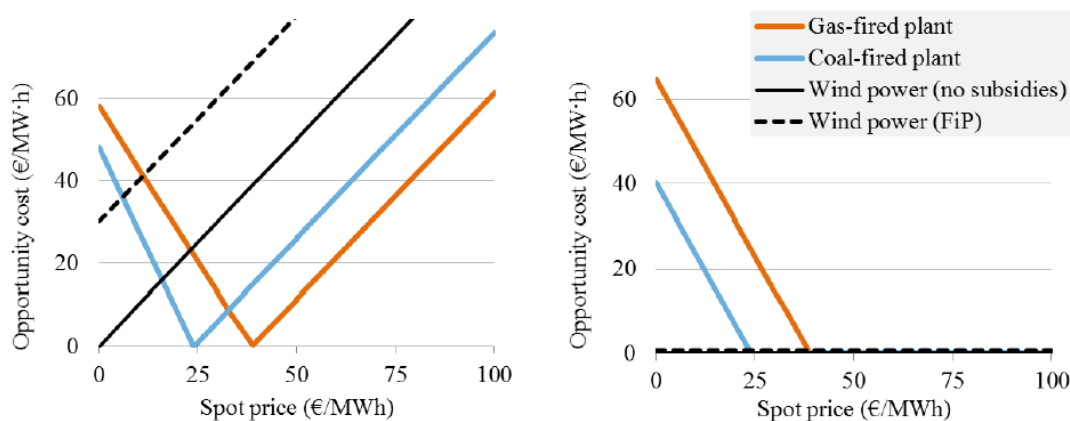

Figure 15: Relationship between the reserve cost and the electricity spot price

Source: Hirth and Ziegenhagen (2015)

To factor in the close relationship between the ancillary services costs and energy prices in jurisdictions (such as the ERCOT market, for example), ancillary service offers are co-optimised as a part of the day-ahead market clearing. This means that market participants do not have to include their expectations of forgone energy sales in their capacity offers for ancillary services. As a result of ancillary services clearing prices explicitly accounting for the value of energy in the day-ahead market, ancillary services prices are highly correlated with day-ahead energy prices.²⁷

Another important aspect related to the ancillary services markets is the degree to which these markets are non-discriminatory and open to all technologies. In a number of European countries, the ancillary services markets feature elements which implicitly discriminate between technologies (e.g. long auction periods), preventing certain VRE generators, electricity storage and the demand side from participating.²⁸ Many such barriers are eliminated with a greater time granularity in the ancillary services markets, as seen in co-optimised systems, such as ERCOT.

Table 8 below summarises the criteria of a market design which yields efficient short-run prices. For each area, we identify the gap between the status quo and the benchmark design outlined above and propose how the current market design could be reformed.

²⁷ However, real-time co-optimization of energy and ancillary services is not yet implemented.

²⁸ On barriers for DSR participation, see for example, Smart Energy Demand Coalition (2011).

Benchmark market design elements	Potential issues	Gaps/issues in countries surveyed
Market price signal reflecting real-time market conditions	VRE forecast errors increase the difference between day-ahead market and real-time reality	Focus on day-ahead rather than intraday Barriers to trade across time horizons Distortive balancing pricing rules
Credible scarcity pricing	Muted scarcity prices increase costs for consumer without triggering investments Risk of missing the reliability standards	Distortive market power and manipulation legislation Lack of explicit instruments allowing price spikes during shortage
Efficient valuation of ancillary services and reserves	Existing/cheap flexibility sources not activated Unnecessary must-run of conventional plants	Lack of ancillary services products (operating reserves) Technology-specific balancing responsibility Discriminatory access to ancillary services markets, including demand-side response

Table 8: Benchmark market design elements – design of spot and ancillary services

Source: FTI-CL Energy and NEON

5.4. LOCATIONAL PRICE SIGNALS

5.4.1. Benchmark market design

Increasing distance between generation and consumption induced by the increased VRE shares would require better coordination between the network operation and the dispatch of VRE and flexible generation in the short term, and the network and generation investment in the longer term.

Such coordination can be achieved through the introduction of locational differentiation of energy and ancillary services products and prices perceived by generators and/or customers. Such locational price differentiation can be achieved through nodal or zonal prices or even through network injection charges.

The IEA 2016 study makes a strong point about the importance of the locational granularity for the design of a future electricity market, suggesting that:

“As decarbonised electricity systems become more volatile, system operators need to take action to ensure prices correspond to actual marginal generation costs. Market design needs to provide a high resolution of the physical reality of the network”

The main objective of the benchmark market design with respect to locational price signals is thus to ensure energy prices that differ between locations (through zonal and nodal prices or locational grid charges).

5.4.2. Bridging the gaps

The economic value of electricity is different between locations, because of transmission constraints and losses. For example, to deliver electricity from a remote offshore wind park to consumers requires more transmission and distribution investments than to deliver electricity from a solar PV plant installed at the location of consumption (see Section 8 below). The former also results in more power losses. Ideally, market design should signal this difference in value to investors so they can take informed decisions. For

example, a solar PV plant may be preferable to a wind park even if it has slightly higher levelised generation costs. This is because, being located at a high-value location, its economic value is higher from a system perspective. A benchmark market design signals this to investors by offering a higher price in such locations.

More specifically, a benchmark market design provides energy prices and/or grid fees that are differentiated by location such that transmission/generation coordination is ensured and the costs of transmission and the physical constraints of electricity grids are reflected.

This could be implemented in the form of location-specific grid fees and/or location-specific energy prices. Grid fees can differ from location to location both in terms of grid connection and grid usage (injection) fees. Energy prices can differ in each node of the transmission grid (nodal pricing) or grouped in larger areas (zonal pricing). Hence there are four design options for locational price signals, ordered in increasing accuracy (but also increasing complexity of implementation):

- **Locational grid connection charges.** An implementation of location-specific network connection fees means that investors pay a different charge to the system operator to connect their plant, depending on the location. Such charges exist in most jurisdictions today, but often shallow, rather than deep, charges are calculated, such that costs that occur beyond the nearest substation are not included.
- **Locational grid injection charges.** Location-specific network usage fees means that generators pay a different grid injection fee depending on the location of their plant. Sweden is an example for a power system where such fees prevail. This requires, of course, that generators pay injection fees at all – in many power systems, only consumers pay such fees and a “G-component” (generator component) is missing. Locational grid injection charges reflect the locational difference in value better, as they not only reflect one-off investment costs, but also losses.
- **Zonal energy prices.** Zonal energy prices are implemented in a variety of jurisdictions, including Australia’s NEM, the four European Nordic markets, and Italy. In these jurisdictions, spot prices vary between bidding areas. Compared to locational grid injection charges, they have the additional advantage of reflecting costs and constraints dynamically, i.e. at a specific moment in time. At times when there are no transmission constraints, prices converge; when there are constraints, they differ.
- **Nodal energy prices.** Many North American markets implemented nodal prices (as well as locational marginal pricing). Here, prices might differ not only between a handful of bidding areas, but between each transmission node. Texas’ ERCOT market, for example, features around 10,000 locational prices. Compared to zonal prices, this has the advantage of being more exact. Also the ability to exercise market power (“gaming”) can be reduced.

Benchmark market design elements	Potential issues	Gaps / issues in countries surveyed
Ensure energy prices that differ between locations	Locational network connection charges is a one-off and geographically rough price signal	Location-specific injection charges implemented in many countries, but usually only shallow, as opposed to deep, connection fees
	Locational network injection charges are static (time-invariant) and geographically rough price signal	Location-specific injection charges implemented in some countries, such as Sweden
	Zonal energy prices are dynamic (time-variant) but geographically rough price signal	Zonal prices implemented in Australia (NEM), as in some European countries including Nordic countries and Italy
	Nodal energy prices are dynamic and geographically precise price signal	Nodal prices implemented in Texas (ERCOT), as in many North American markets

Table 9: Benchmark market design elements – design of locational signals

Source: FTI-CL Energy and NEON

As a general principle in Europe, each country corresponds to a market area and exchanges within that market area are not constrained ex-ante by network capacities. Market players can therefore buy and sell energy from any generators located in this area to any consumers within this area without facing additional transmission charges. Congestions are dealt with by TSOs by re-dispatching generation close to real time through re-dispatch or balancing markets.

Australian NEM also features a zonal market with five zones corresponding to five regions: Queensland, South Australia, Tasmania, Victoria and New South Wales. The technical capabilities of cross-border interconnectors set upper limits on interregional trade.

However, zonal systems have already exhibited a certain vulnerability to VRE production. For instance, there have been examples of TSOs having to limit the capacity of the cross-zonal transmission capacity because of the variation of the wind production and because of the inability of the zonal system to allocate the power flows induced by wind power economically.

One first general option is to define price zones or price nodes between which electricity trading will be limited by network constraints. This is already done today between member states and within several countries such as Italy, Sweden, Norway or Denmark. ENTSO-E is currently running a bidding zone review, analysing the possible benefits of reconsidering the national zone structure and possibly introducing sub-national zones in countries such as France and Germany.²⁹ The question of zonal configuration and possible nodal market remains very controversial and there is strong opposition to smaller zones/nodes in many European jurisdictions.

²⁹ Splitting bidding zones within national borders could be done without violating the national regulation requiring “equalization tariffs” for consumers (e.g. péréquation tarifaire in France). For instance, In Italy, a nation-wide price is paid by consumers while generators receive zone-specific price. .

In the US, several states have even opted for nodal pricing, such as in PJM, New York, New England, California, and Texas. In case of grid constraints, relatively cheap generators in exporting zones or nodes might not be dispatched whereas more expensive generators will be called in import-constrained areas, resulting in higher prices in these areas.

ERCOT provides a recent example of transition from zonal to nodal market as it originally started as a zonal market. Whenever congestion within zones occurred, ERCOT had to perform real-time countertrades (re-dispatch) to relieve such congestion. Dealing with intra-zonal congestion was found to create cost shifts between customers located in congested and uncongested areas and to significantly impact the efficiency by increasing the cost production due to the out-of-merit (re-dispatch) payments. Since December 2010 ERCOT has been operating as a nodal market.³⁰

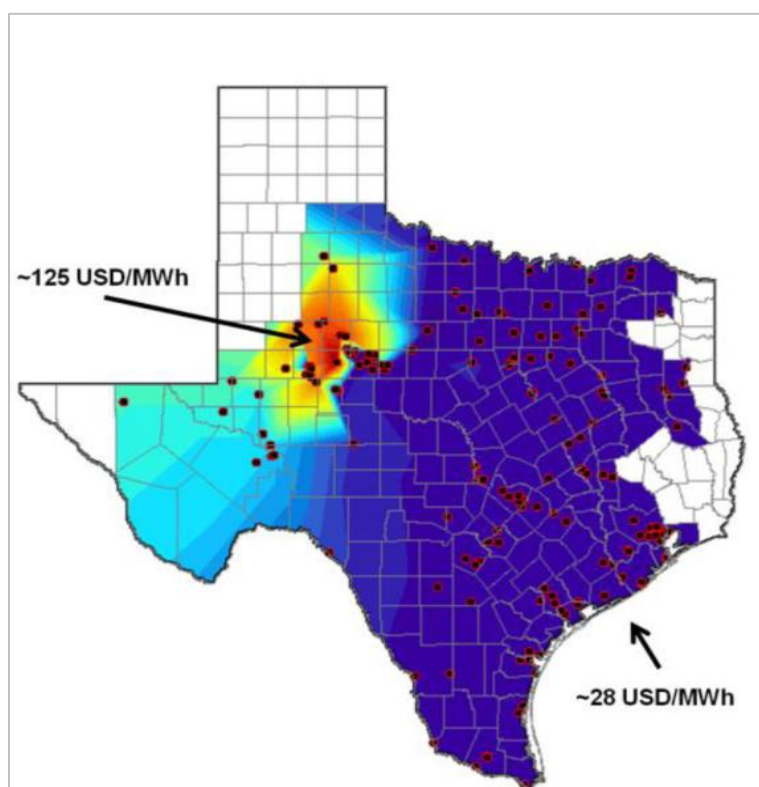

Figure 16: Nodal day-ahead price differences in Texas (example of one moment in time)

Source: ERCOT.

5.5. DEVELOPMENT OF HEDGING PRODUCTS

5.5.1. Benchmark market design

Increased capital intensity and price variability induced by high VRE shares would increase the need for investors to be able to lock-in the variable market revenues in advance. In order to achieve this, the market design should ensure the presence of liquid long-term forward hedges (over the period of several years) on a number of products traded in the short-term market. In the energy-only market prototype, such hedging is on a voluntary basis between market participants. Hedging products that are required by market participants first appear on the over-the-counter markets and then standardised products become

³⁰ Potomac Economics, 2013, ERCOT State of the Market Report 2012.

tradeable on power exchanges. One could expect that, as power systems evolve, new hedging products would emerge.

However, natural development of the forwards market may face various obstacles and regulatory and policy interventions may facilitate the access of market participants to the forward markets and foster liquidity in such forward markets.

The benchmark criteria to develop hedging products can be summarised as:

- Liquid long-term markets across all timeframes;
- Financial products providing hedges against spot price volatility; and
- Forward financial transmission rights.

5.5.2. Bridging the gaps

The flip side of scarcity pricing is that market participants are exposed to greater price spikes and imbalance risks. As a result, hedging products play a critical role in allocating and transferring risks efficiently in a well-working energy only market, both in the short and long term. More fundamentally, the development of appropriate hedging instruments is a key pre-condition for an efficient functioning of energy only markets.

Liquid markets across all time frames

One common problem of the forward electricity markets is the liquidity across various time-frames. In the UK, Ofgem has analysed the evolution of liquidity indicators and has found a dramatic decrease in the churn rate (one of liquidity indicators) from about 7 in 2001-2002 to about 3 in 2008. Ofgem has considered that factors contributing to low liquidity included the size of the market, the extent of demand side participation and the policy environment, trading arrangements, collateral requirements as well as vertical integration of market participants.

Ofgem has concluded that the best option to address the liquidity problem in general would be through targeted measures, such as a Market Maker Obligation (MMO). The Market Making Obligation requires certain participants to simultaneously quote a firm bid price (the price at which it is willing to buy) and offer price (the price at which it is willing to sell) for specific forward products with a small price spread between the two offers. Market Making provides all participants with continuous opportunities to trade forward products.

Financial products providing hedges against spot price volatility

In practice, most current markets (e.g. in the EU) have not yet developed the financial hedging products that would be needed in the system where high shares of low-variable cost VRE induce large price volatility. However, necessary hedging products may develop naturally when price volatility increases and market participants get a greater incentive to hedge (e.g. renewable generators become balance responsible).

Australia provides an interesting example of a market in which hedging contracts have naturally emerged. The high price spikes occurring occasionally in the NEM cause a risk to market players that have not covered their position in the market. If the price goes up to several thousand dollars per MWh, and the retailer has not covered their position with financial instruments, the cost will be massive. The same applies for portfolios with a large share of wind generation.

This risk has enabled liquid financial contracting between the generator and the retailers in the NEM. According to Australian Energy Market Commission, a number of financial contracts are used to hedge the financial risk of the volatile spot electricity market.³¹ A contract used specifically to cover retail suppliers against the price spikes is called a “cap contract”. In this contract, parties agree on a strike price for the cap. A common strike price for a cap contract is \$300/MWh. If the spot price exceeds this strike price, the seller of the cap contract (usually a generator) must pay the buyer of the cap contract (usually a retailer) the difference between the actual spot price and the strike price. For example, if the pool price is \$1000/MWh, under the \$300 strike price contract the generator would pay \$700/MWh to the retailer. In return, the buyer of the cap will pay the seller a fee, which provides the generator with an extra source of revenue.

There is considerable interest today in Europe in developing innovative hedging products and instruments to deal with power price volatility of intraday markets induced by the growth of renewables. One example of new hedging products is the “Cap Future” introduced by the central European power exchange EEX in September 2015. This futures product hedges consumers against the risks of price spikes that may occur on the German intraday market associated with high RES volatility.³²

Hybrid markets discussed in Section 7 introduce mandatory hedging instruments in addition to the hedging instruments that may develop on a voluntary basis.

Forward financial transmission rights

In a market with greater diversity in locational prices (e.g. a nodal or a zonal market with small zones), the forward market may need to feature a multi-zone hub design. In such a design, hedging contracts are created for a group of bidding zones and linked to a hub price, which represents a sort of average day-ahead price within this group of zones or nodes. In Europe, such a multi-zone hub design is implemented in the Nordic countries and in Italy. In the US, multi-node hubs are used in nodal markets, such as PJM, New York and New England.

While the liquidity of hedging products linked to a hub price is usually good, market participants need to hedge the difference between the hub price and the spot prices of individual zones or nodes. Such hedges are typically provided by Financial Transmission Contracts (a.k.a. Contracts for Differences), which pay their holder the difference in price between a zone or node and the hub. However, the experience of the Nordic market suggests that CfD are not liquid enough.³³

³¹ AEMC (2013)

³² The payment threshold for the Cap Future is fixed at a price of € 60 per MWh. This threshold (“Cap”) indicates the price as of which the buyer of a Cap Future receives a payment from the seller, for an hourly product traded on the German Intraday Market of EPEX SPOT. The amount of the payment corresponds to the difference between the market price, measured by the ID3-Price, and the amount of the cap. This new index is calculated on a daily basis for all delivery hours on the German intraday market and published by EPEX SPOT.

³³ ACER (2014)

Benchmark market design elements	Potential issues	Gaps / issues in countries surveyed
Liquid markets across all time frames	Lack of forward market liquidity	Low liquidity in forward markets indicated by Ofgem in the UK
Financial products providing hedges against spot price volatility	High risk exposure of market participants to price volatility	Development of products for price volatility hedging requires volatility to materialise first
Forward financial transmission rights	Need to hedge against the locational price differential	Contracts allowing locational hedges may not be liquid enough

Table 10: Benchmark market design elements – hedging products

Source: FTI-CL Energy and NEON

6. VERTICALLY INTEGRATED UTILITY

6.1. INTRODUCTION

This prototype refers to markets where the incumbent is a vertically integrated utility with social obligations to maintain the security of supply. In such markets generation operated by the incumbent is regulated, while possibly allowing Independent Power Producers (IPPs). In the vertically integrated system, both the dispatch and generation investment decisions are centralised.

Examples of this market prototype include South Africa as well as some markets in the US.

6.1.1. Case study: vertically integrated system in South Africa

Another interesting example of a vertically integrated utility we use as a case study in this report is South Africa. South Africa's electricity sector is a vertically integrated utility where the state power utility, Eskom Holdings Limited, supplies 96.7% of the electricity in South Africa (45% of Africa's electricity supply). As a vertically integrated utility, Eskom handles all functions of generation, transmission and distribution. Eskom is also the single buyer from Independent Power Producers.

Renewable energy currently makes up only about 0.5% of production with hydroelectric, wind, and solar power. For hydroelectric, there are six hydroelectric power plants containing 600MW capacity and two hydroelectric pumped storage stations with 1,400MW from 2011. From 2009 to 2015, three hydroelectric plants have been built. For wind, there was 560MW of capacity in 2014, a large jump from the end of 2013 when there was only 10MW. South Africa continues to place bids to build more wind power plants with power capacities of 3,000 to 5,000MW in the next few years.³⁴ South Africa had 41MW of capacity of solar power in 2012.

6.1.2. Case study: vertically integrated utilities in United States

Vertically integrated utilities that own and operate generation, transmission, distribution and retail supply under some regulatory oversight can be found in a number of jurisdictions. For example, despite an advanced deregulation process in many states in the U.S., electricity is still mainly produced by vertically integrated utilities in a number of states.

In particular, the electric grid in the Western North America, known as the Western Interconnection (WI) is managed by 37 distinct Balancing Authorities (BAs) of various ownership structures. Many of the Balancing Authorities are vertically integrated utilities such as AZPS (Arizona Public Service Company), PSCO (Public Service Company of Colorado), PACE and PACW (PacifiCorp East and West), PNM (Public Service Company of New Mexico), etc.

³⁴ GWEC (2011)

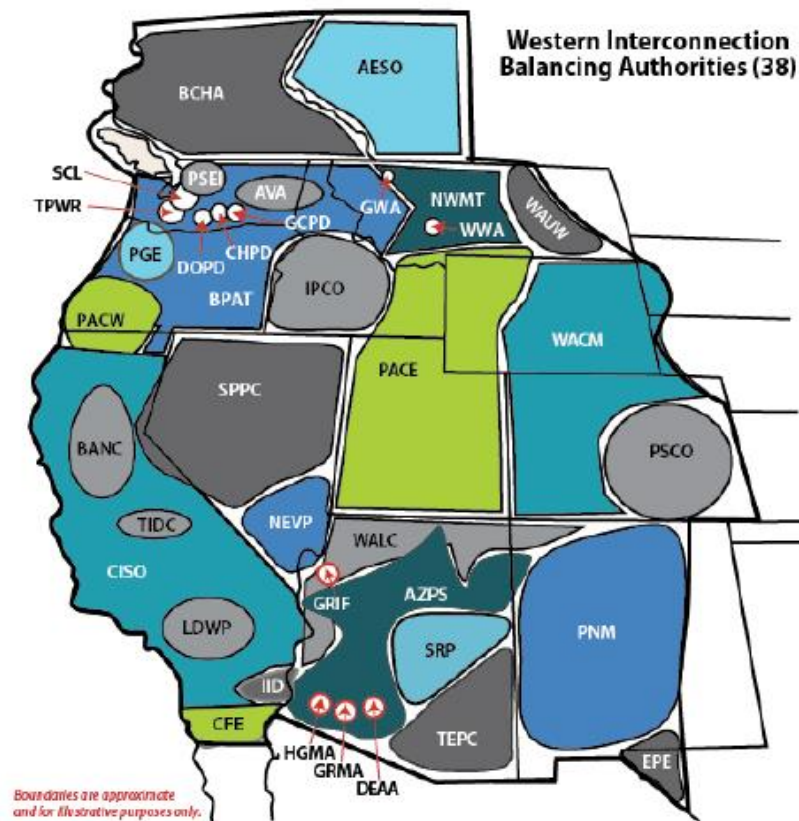

Figure 17: Western Interconnection Balancing Authorities:

Source: WECC (2013).

The balancing authorities (BAs) are responsible for dispatching generation, procuring power, operating the transmission grid reliably and maintaining adequate reserves. Although the BAs operate autonomously, they actively trade electricity among each other in bilateral trades and have joint transmission-planning and reserve-sharing agreements. Many of these utilities have implemented rules for open access to their transmission grids for IPPs and independent generators and actively trade power between each other. These utilities operate under state legislation that sets energy portfolio standards requiring utilities to meet a certain percentage of their sales with designated resource types, generally a defined set of renewable ones.

6.2. CRITICAL ELEMENTS OF THE BENCHMARK MARKET DESIGN

A vertically integrated utility owns and operates the bulk of the production capacity in its control area. It optimises the dispatch of its generators and assures the security of the network. It also makes necessary investments and upgrades in generation capacity, as well as in the transmission and distribution networks. It operates the distribution grid and serves final customers.

In the vertically integrated market prototype, VRE generation can be developed by the incumbent. However, due to the distributed nature of VRE generation, it is likely that some of it will also be developed by independent power producers (IPPs) and prosumers.

A vertically integrated utility has full control over the optimisation of its portfolio in the short-term (short-term energy scheduling) and in the long-term (investment and upgrade decisions). As such, a number of

challenges of high shares of VRE associated with short-term dispatch and co-ordination between VRE, conventional generation and networks do not seem to apply in the case of the vertically integrated utility.

On the other hand, investments made by the vertically integrated utility and the tariffs they charge the customers are typically reviewed and approved by regulatory bodies. This review verifies the extent to which the investments made by the vertically integrated utility benefit the customers before allowing the utility to roll the investment costs into the customer tariffs.

This suggests that the main features of the market design of the vertically integrated power system that are critical in facing the challenges presented by VRE are:

- The regulatory framework. Since the investment of the vertically integrated power company is usually done under regulatory supervision, a number of long-term market design goals can be accomplished through the structuring of the regulatory oversight of the vertically integrated monopolist;
- Rules for third-party access. The rules for the third-party access are important in case VRE is (or is expected to be) developed by independent power producers or the auto generating customers; and
- Trading arrangements with other utilities. A challenge induced by VRE for the market design of the vertically integrated power system prototype is the increased need to trade with neighbouring utilities to access the flexible resources necessary to counter the VRE output variations.

Table 11 below summarises these elements of market design.

Element of market design	Challenge presented by VRE
Regulatory framework	Achieving the optimal generation mix under the decarbonisation constraints, inducing deployment of innovative technologies (e.g. storage and DSM, etc.). Incentives for efficient short term cost based dispatch.
Rules for the third-party access	Operational timeframe shift towards real-time System stability through ancillary services and demand response
Cross border trading arrangements	The shift of operational timeframe to real-time

Table 11: Critical elements of the market design in a vertically integrated market prototype

Source: FTI-CL Energy and NEON

In the remaining subsections, we discuss each of the critical market design elements of the vertically integrated prototype. We identify the ‘ideal’ benchmark market design, identifying the gaps with the currently existing markets and providing high level policy recommendations for the evolution of the market design element.

6.3. REGULATORY FRAMEWORK

6.3.1. Benchmark market design

To meet the long-term investment efficiency criterion, the regulatory body should also have mechanisms at its disposal to induce the monopoly to make investments that yield the most social benefit, including the social benefit from decarbonisation. Such regulatory mechanisms may be needed for example to ensure the incumbent has incentives to invest in renewable generation in order to meet the applicable environmental targets and to provide fair investment environment for IPPs.

The regulatory framework of the vertically integrated monopoly should also aim at ensuring an adequate return on investment and avoid over-investment incentives. The regulated rate of return earned by vertically integrated utilities reduces the investment risk, while potentially putting excessive investment risk on the customer. The regulatory framework should ensure an efficient risk sharing between customers and the utility.

Objectives for the benchmark regulatory framework can be summarised as follows:

- Regulation of the vertically integrated utility should provide incentives for efficient development of VRE, distributed generation, energy efficiency and flexible generation both by the incumbent and by IPPs.
- Regulatory framework should ensure adequate return on investment and avoid incentives to over-invest.

6.3.2. Bridging the gaps

Inefficient regulation of vertically integrated utilities was one of the main reasons for deregulation process in many countries. These utilities were often considered to be overly protected from the investment risk and many felt that their operations resulted in overinvestment, which was too costly for customers.

A specific example of regulation of the vertically integrated utility Eskom in South Africa reveals a number of operation and planning problems related to the utility's regulation. These problems were, in particular, thought to be responsible for recent severe power shortages in South Africa. In particular, some maintenance operations were delayed, which could have resulted in further problems later on. Also, the planning and procurement of new capacity by Eskom has resulted in cost overruns that have put pressure on Eskom's balance sheet.³⁵

Transition to the market with high shares of VRE may present a number of challenges under the vertically integrated market paradigm:

- Transition to the market with high shares of VRE will likely involve a slower transmission level electricity load growth, as a result of increased use of distributed energy resources, such as energy efficiency and distributed generation. At the same time, the electric industry experiences the need for new investments, such as the need to replace aging infrastructure, increased transmission needs, requirements to reduce environmental impacts and pressure to modernise the electric grid.
- In a market with high shares of VRE, planning becomes more complex given the uncertainties over the diminishing cost of clean technologies, the emergence of new technologies (such as demand-side resources) and decentralised storage. Interface between national and local level becomes critical and regulation needs to incentivise efficient local and national planning.
- Similarly, short-term operations become more complex, because of the need to rebalance the system closer to real time, two ways communication, involvement of prosumers, etc.

Combined, these factors simultaneously increase the need for utility capital expenditures while reducing the revenue from sales growth that the utility has historically relied upon. In such an environment, traditional methods of regulation for vertically integrated utilities, such as Cost-of-Service Regulation or Performance-Based Regulation (PBR), may not be as efficient in meeting objectives.

³⁵ Financial Mail (2014)

Some jurisdictions and stakeholders have begun to investigate new regulatory and utility business models. Several of these proposals focus on PBR mechanisms, with the overall goal of creating financial incentives that are based more on performance and less on recovery of costs. Several examples of such modifications to the way that PBR is currently can be found in the United States. These modifications include:

- Expansion of the types of performance metrics applied to utilities to include emerging performance areas such as system efficiency, customer engagement, network support services, or environmental goals.
- Establishing longer periods between rate cases. This is intended to increase the magnitude of the financial incentive to increase productivity and reduce costs between rate cases.
- Providing more up-front guidance from regulators and stakeholders with regard to future major capital expenditures. This is intended to provide utilities with greater flexibility and incentives to adopt innovative and emerging technologies and practices.

For example, in 2010, Hawaii has conducted a review of the regulating procedures for its electric utilities to encourage renewable resources, distributed generation and energy efficiency. Hawaiian PUC has adopted a number of performance metrics for tracking utilities' ability to achieve renewable energy goals, ensure reliability and reduce costs. The performance incentive mechanism has also affected the Integrated Resource Planning, setting performance metrics for the level of stakeholder engagement, the breadth of the resource evaluation including demand-side options, energy efficiency, storage, distributed generation, etc.³⁶

Another important dimension to incentivise through regulation is innovation. Discussion on the UK RIIO regulatory framework for DSO (which we present later on in this section) provides a good example of such regulation designed to stimulate innovation.

³⁶ Synapse (2015).

Benchmark market design elements	Potential issues	Gaps / issues in countries surveyed
Provide incentives for efficient development of VRE, distributed generation, energy efficiency and flexible generation both by the incumbent and by IPPs.	Difficulty to predict the cost of clean and emerging technologies	Biased planning objectives and cost overruns
Ensure adequate return on investment and avoid incentives to over-invest.	Rate-of-return regulation providing incentives to over-invest	System 'Gold-plating' and increased cost to customers

Table 12: Market design objectives, issues and gaps for regulatory framework

Source: FTI-CL and Neon

6.4. RULES FOR THE THIRD-PARTY ACCESS

6.4.1. Benchmark market design

The benchmark rules for the third-party access should ensure that the incumbent does not discriminate against the IPPs in favour of its own generators with regards to dispatch. They also define the payment provided by the incumbent for the energy it purchases from IPPs, e.g. through network tariff connection and usage charges, that drive the IPPs investments.

In case IPPs represent a significant share of VRE, the rules of the third-party access need to be defined in such a way as to ensure efficient short-term dispatch and long-term investment by IPPs. These benchmark criteria can be summarised as follows:

- Avoid discrimination against IPPs for the short-term dispatch; and
- Ensure efficient investment by IPPs (timing and location).

6.4.2. Bridging the gaps

One of the critical elements of the third-party access for IPPs is to identify the entity responsible for the buyer function. For example, in South Africa, IPPs remain in a difficult position to compete with Eskom in the current settings. For renewables IPPs, Eskom remains the single buyer of electricity (with the exception of off-grid installation).

The possibility for IPPs to sell electricity directly to third parties, particularly energy-intensive industries which seek to secure low-cost and consistent supply, is currently limited. The possible transfer of some transmission-related functions from Eskom to the Independent Market and Systems Operator (ISMO) may change the situation.³⁷ No policy explaining the market architecture of the Eskom as a single buyer in detail has been published yet, leaving the role and function of the ISMO unclear.

WECC (Western Electricity Coordinating Council) covers the Western Interconnection area in the US area and its members include a number of vertically integrated utilities (e.g. Arizona Public Service, Public Service Company of Colorado, PacifiCorp). The vertically integrated utilities in the WECC operate their transmission systems in accordance with FERC-approved open access transmission tariff (OATT). This tariff

³⁷ Montmasson-Clair et al (2014)

obliges them to provide access to IPPs on a non-discriminatory basis, under approved OATT rates. A possible issue with the access of IPPs in the WECC could be associated with the so-called “Rate pancaking” (i.e. accumulation of transmission charges by wheeling power through two or more transmission systems).³⁸

Benchmark market design elements	Potential issues	Gaps/issues in countries surveyed
Avoid discrimination against IPPs for the short-term dispatch	Discrimination against the energy sales from IPPs	Absence of clear single buyer functions and open access rules (SA)
Ensure efficient investment by IPPs (timing and location)	Barriers for IPPs to get access to the incumbent’s network	Absence of clear single buyer functions and open access rules (SA)

Table 13: Market design objectives, issues and gaps for third-party arrangements

Source: FTI-CL and Neon

6.5. TRADING ARRANGEMENTS WITH OTHER UTILITIES

6.5.1. Benchmark market design

A challenge induced by VRE for the market design of the vertically integrated power system prototype is the increased need to trade with neighbouring utilities to access the flexible resources necessary to counter the VRE output variations. This implies the need for more transactions with other utilities and arrangements necessary to facilitate such transactions. The design of such rules should meet the short-term dispatch efficiency market design criteria.

The benchmark objective for such trading arrangements are:

- Ensure efficient short-term trade with neighbouring utilities; and
- Introduce bilateral and/or organised energy cross-border trading.

6.5.2. Bridging the gaps

WECC has a long history of bilateral power trading arrangements between the participating utilities, both OTC and on the trading platforms, such as Intercontinental Exchange (ICE). Power has been traded at a number of trading hubs in WECC since the 90s.³⁹ The main trading hubs are COB (California-Oregon Border), Palo Verde (Arizona), and Mid-Columbia (border between Oregon and Washington). Traditionally, daily trades have been conducted on a bilateral basis at the hourly frequency. Balancing Authorities in the Western Interconnection also participate in the Reserve Sharing Program, allowing a regional approach to the provision of reserves.⁴⁰

In addition, to accommodate variable generation, studies have been conducted evaluating the benefits of introducing intra-hour energy scheduling across WECC.⁴¹ To address the wind integration issues, a joint initiative is ongoing to ensure that cooperation is done on a closer to real-time timeframe. This initiative

³⁸ NREL (2012)

³⁹ Braziel (1998)

⁴⁰ Northwest Power Pool (2015)

⁴¹ WECC (2013)

includes within-hour transmission purchase and scheduling, allowing better use of transmission capacity between Balancing Authorities.⁴²

Eskom is part of the Southern African Power Pool, a cooperation of national utilities in the region that aims to create a common market in Angola, Botswana, the Democratic Republic of the Congo, Lesotho, Mozambique, Malawi, Namibia, Swaziland, Tanzania, Zambia, Zimbabwe and South Africa. However, development of power trade with neighbouring countries and utilities has been constrained by the lack of trust and confidence among pool members, inadequate generating capacity and reserve margins, lack of legal framework for electricity trading, lack of rules for access to the transmission grid (including wheeling charges) and lack of regional regulation and appropriate mechanism or dispute resolution.⁴³

Benchmark market design elements	Potential issues	Gaps/issues in countries surveyed
Ensure efficient short-term trade with neighbouring utilities	Absence of regional regulation and legal frameworks for power trading	Lack of cross-border trading
Introduce bilateral and or organised energy cross-border trading	Absence of trading possibilities	Lack of trading and liquidity

Table 14: Market design objectives, issues and gaps for cross-border trading

Source: FTI-CL and Neon

⁴² Energy Strategies (2009)

⁴³ Niyimbona (2005)

7. HYBRID MARKET

7.1. INTRODUCTION

In the hybrid prototype, although dispatch decisions remain based on wholesale power prices, generator investment decisions are supplemented by additional risk transfer or coordination mechanisms induced by the policy maker. Although the generator investment decisions could be made through a market process (e.g. capacity market, tenders for long term contracts, etc.) the demand in this process is determined by the requirements set through a specific coordination mechanism. Thus, a common feature of these systems is the presence of mandatory risk hedging instruments induced by the requirements imposed by the policy maker.

Hybrid systems involve some form of public intervention in either security of supply or determination of the generation mix. These hybrid models vary widely, depending on the objective and type of public intervention. There is a range of hybrid models, which depend on the scope of the regulatory intervention to coordinate investment decision and to align it with policy objectives.

Our review of international experiences focused on countries which keep a significant role for the market, i.e. ‘hybrid power markets’, in which the market remains the core driver of market participants’ operating decisions, and where complementary mechanisms support investment. The most relevant case studies for our study are the hybrid market arrangements found in some Latin American countries (such as Brazil or Chile), in some North American states (such as Ontario) as well as in the UK.

This hybrid market framework ensures competition in two steps, as described in Figure 18 to separate between:

- Long term investment decisions largely driven by the hybrid process (e.g. auctioning of long-term contracts, i.e. competition “for the market”); and
- Short term system optimization (dispatch) based on spot market prices (i.e. competition “in” the market”).

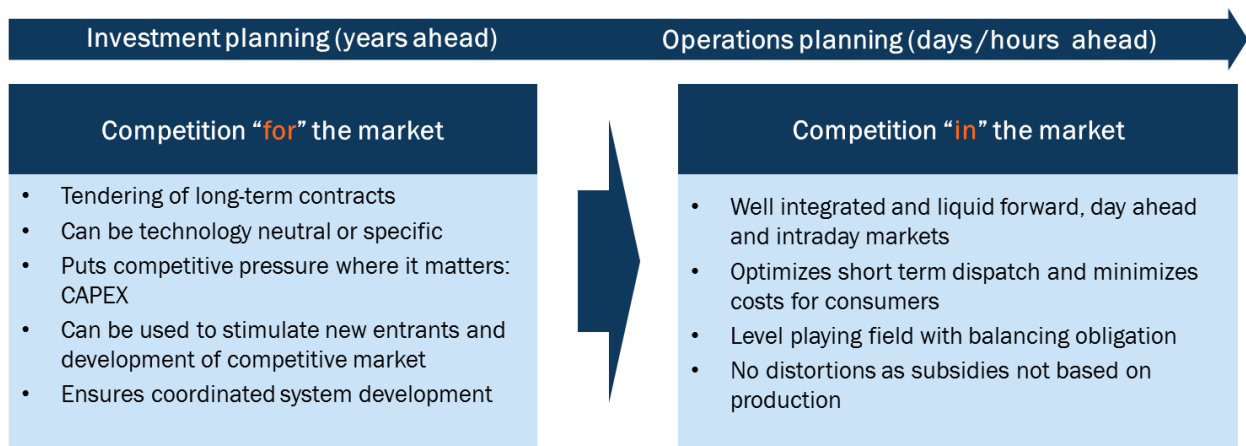

Figure 18: Two step competition in hybrid markets

Source: FTI-CL Energy

Below we provide a brief introduction to the process that led to the implementation of hybrid markets in Brazil, Ontario and the UK.

7.1.1. Case study: hybrid market in Brazil

The first wave of Latin American reforms put the standard electricity market approach in place. In the early 1980s, the electricity sectors in Latin American countries were dominated by vertically integrated monopolies. From 1982 onwards they began to reform, following a model of partial liberalisation with centralised cost-based dispatch. Prices for small consumers remained regulated. In the early 2000s, dissatisfaction with this approach grew, in particular with regards to price regulation. Volatile spot prices were failing to stimulate timely investment and this had led to rolling blackouts in some countries. There was no stability in long term generation revenues, hampering the ability of new capacity projects to obtain project-finance.

In light of these problems, there was a second wave of market restructuring in the early 2000s. The timeline of these reforms for different countries in South America can be seen in Figure 19. This approach led to the introduction of hybrid markets, with long-term contracts being implemented to support and coordinate investment.

Brazil is particularly relevant for our study as it introduced substantial electricity market reforms in 2004 to correct problems with under-investment in new capacity. Highly volatile spot market prices and the potential for government intervention in prices increased the risks for merchant generation and led to insufficient investment.

The key objectives of the reforms were firstly to introduce better incentives for investment and secondly to guarantee that there would be enough capacity to meet the growing load in the future. The Brazilian electricity system is characterised by a strong demand growth (4.1% on average per year over 2000-2010), and a very significant share of hydro generation (80%), which implies that guaranteeing security of supply needs to account for the possibility of dry years.

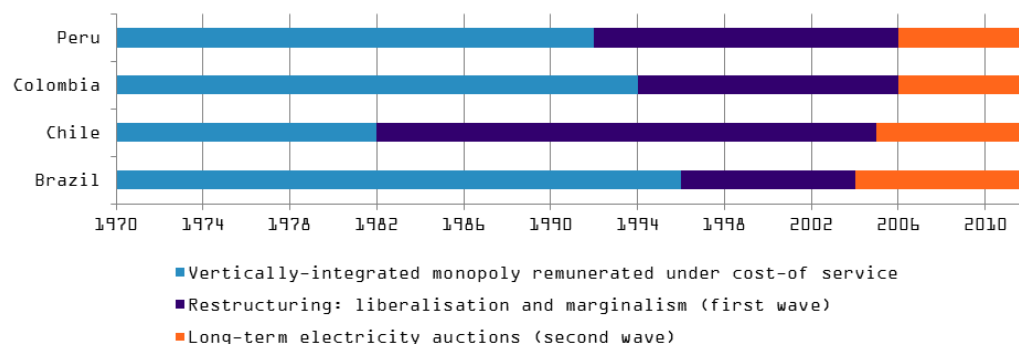

Figure 19: Timeline of regulatory reforms in in South America

Source: Mastropietro et al (2014)

7.1.2. Case study: hybrid market in Ontario

The deregulation of the Ontario market started in 2002. As a result of the deregulation process, residential prices have become directly exposed to wholesale price volatility. When the wholesale prices rose sharply soon after the reforms, politicians felt compelled to intervene to protect customers. This was despite the fact that the wholesale prices rose mostly due to market fundamentals (high demand, driven by the hottest summer in 50 years, reduced generating capacity, and limited import capacity).

The new Ontario government that came to power shortly after deregulation wanted to demonstrate political strength in the solution of the problem and implemented quite radical reforms, freezing the retail

prices and introducing the Single Buyer model in 2004. An additional reason for the introduction of the Single Buyer model was the commitment taken by Ontario in 2002 to phase out coal-fired generation by 2015.

Ontario Power Authority (OPA), established by the Ontario government in 2002 and existing as an independent agency until 2014, acted as a single buyer, with responsibility for long term forecasting and planning of the state's future energy needs. It developed integrated forward-looking plans and provided advice to the government on the overall policy priorities, including the phasing out of coal and promotion of renewable energy sources.

In its role as a single buyer, the OPA procured capacity it deemed necessary, based on the forward-looking plan. The OPA struck long-term contracts with power generators for capacity and passed the cost to the customers through the retail tariffs. There are different approaches depending on the technology-type and age of the generator.⁴⁴

Since 2014 OPA has merged with the Ontario's Independent Electricity System Operator (IESO). Since then, IESO has OPA's statutory objectives and powers for planning and procurement, grandfathering the former procurement contracts.⁴⁵

7.1.3. Case study: hybrid market in United Kingdom

The Electricity Market Reform (EMR) has been a radical reform of the UK power market framework. The UK is widely considered to be a pro-market country, yet it has implemented changes to the power market to help it work more efficiently while reconciling the diverging objectives of decarbonisation, security of supply and affordability.⁴⁶

This approach was fiercely criticised as a return of central planning. However, the new structure was based on market based mechanisms, and so it allows competition both "for the market" and "in the market". The UK has also recognised the role of long-term contracts in facilitating investment at low cost.

The UK EMR introduced four key mechanisms to support the market and provide incentives for investment in clean technology. These mechanisms are:

- Long-term contracts in the form of feed-in tariffs with contracts for difference – to provide clear, stable and predictable revenue streams for investors in low-carbon generation;
- Capacity mechanisms including long-term capacity agreements – to bring forward investment in the amount of capacity needed to ensure security of supply by providing a more predictable revenue stream to capacity providers.
- Carbon price floor – to reduce uncertainty, put a fair price on carbon and provide a stronger incentive to invest in clean technologies; and
- Emissions Performance Standards (EPS) – to provide a clear regulatory signal on the amount of carbon that new fossil-fuel power stations can emit.

⁴⁴ In particular, three mechanisms can be mentioned: a) Generation existing before the reform of 2004 and owned by state owned Ontario Power Generation (OPG) contracted at regulated price and generation owned by private parties through long term PPAs; b) technology-specific Feed in Tariffs (FIT) are offered to new small scale renewable and cogeneration projects and c) negotiations are conducted for specific situations (e.g. OPG's new large nuclear stations).

⁴⁵ Vegh (2014)

⁴⁶ Department of Energy & Climate Change (2010)

Given the above, the UK represents an example of an ambitious and quite radical reform of the electricity market that, although quite different from general market designs in the EU so far, was still made compatible with EU rules and target models. The mechanisms the UK introduced were acceptable for the European Commission as they are mostly market-based, with competitive auctions used to determine CfD strike price and capacity price. As such, they are likely to result in minimal support for generators thanks to these auction-based mechanisms. Furthermore, the European Commission accepted the use of long-term contracts for CfDs and the capacity market, which were justified because of the market failures previously hampering risk hedging.

7.2. CRITICAL ELEMENTS OF THE BENCHMARK MARKET DESIGN

The hybrid power system prototype relies on markets for an efficient short-term dispatch. The challenges created by VRE in the short-term timeframe are therefore very similar to those in the energy-only power system prototype. However, the challenges related to investment are less important as investment does not entirely rely on the short-term markets and its derivatives and is supported by the state-induced mandatory hedging instruments (e.g. long-term capacity or energy contracts).

A distinct feature of the hybrid power system prototype is the integrated resources planning and coordination process, through which the central planner identifies capacity needs and procures necessary capacity. Another feature is the need for the administrator of the mandatory risk hedging instruments (e.g. long-term contracts for capacity) to implement the necessary investment.

This suggests the following broad elements of market design are critical in the hybrid market prototype in order to tackle the challenges presented by VRE:

- **Integrated resource planning / coordination.** Integrated resource planning is a critical point in the hybrid and vertically integrated systems since the central planner would need to assess the real value of RES in a level playing field with other technologies, given the high planning uncertainty. In the presence of high VRE shares, integrated resource planning will become more challenging for a central planner. VRE will make it more important to plan the system with particular regard to the increased capital intensity and variable cost variability, a change in the merit order induced by VRE and the increasing distance between generation and consumption. Mistakes made in the resource planning stage would lead to stranded investments or overcapacity.
- **Interface between centralised and decentralised operational processes.** The structure of the long-term state contracts should contribute to the efficiency of the short-term dispatch and not induce distortions in it. The long-term state contracts should induce the amount and type of assets that are required according to the short-term signals and not undermine scarcity signals for flexibility resources. The interface with the short-term market-based dispatch becomes all the more important as high shares of VRE shift the operational timeframe closer to real-time and set new requirements for Ancillary Services products (as well as new constraints to provide them).
- **Organisation of mandatory risk hedging instruments.** The efficient organisation of the mandatory risk-hedging instruments aimed at promoting investment may take different forms. Often they are in the form of contracts defined by the state-led requirements and their organisation includes a number of notable features, such as the design of the contracts, the contract procurement process and the contract counterparty. The challenge for long-term contracts awarded or induced by the state requirements is to induce investments in sufficient renewable and flexible capacity to achieve the optimal generation mix under high shares of VRE and allow coordination of the investment in generation with the existing and future transmission and distribution networks.

Table 15 below summarises the critical elements of the market design in a hybrid prototype.

Element of market design	Challenge presented by VRE
Integrated resource planning	Increasing distance between generation and consumption Increased capital intensity and price variability Shift of the thermal plants towards mid- and peak-load
Interface between centralised and decentralised processes	Shift of the operational timeframe to real-time New requirements for AS products, and new constraints to provide them
Organisation of mandatory risk hedging instruments	Shift of the thermal plants towards mid- and peak-load Decentralised and scattered generation

Table 15: Critical elements of the market design in a hybrid prototype

Source: FTI-CL Energy and NEON

In the remaining subsections, we discuss each of the critical market design elements of the hybrid market. We identify the ‘ideal’ benchmark market design, identifying the gaps with the currently existing markets and providing high level policy recommendations for the evolution of the market design element.

7.3. INTEGRATED RESOURCE PLANNING

7.3.1. Benchmark market design

The ‘ideal’ benchmark integrated resource planning process would achieve allocation between VRE and flexible resources in an efficient way, using as much information on the demand and technology forecast as is available. Under the benchmark design, the central planner would run an efficient, transparent and non-discriminatory procurement process for the planned capacity.

An efficient resource planning process may be achieved by setting a clear mandate for the planning agency and ensuring its incentives are well aligned through the right governance. For example, an efficient planning process could be achieved more effectively by an independent planning agency rather than by the government or by the incumbent utility. This is because the decisions of the state authorities may be biased by other vested interests.

One can therefore summarise the benchmark market design for the integrated resource planning as contingent on the following specific objectives:

- Efficient resource planning and an efficient procurement process;
- Transparent process for determining investment needs; and
- Efficient governance and incentives of the planning agency.

7.3.2. Bridging the gaps

The international experience with hybrid markets calls for caution in implementation as complementary mechanisms for planning can be counterproductive if not carefully designed. Designing an efficient hybrid market with complementary mechanisms to support system planning and allocate risk efficiently requires:

- A clear definition of roles and responsibilities; and
- Addressing the inefficiency issues of a central planning process

Clear definition of roles and responsibilities

One key issue resides in the responsibilities and independence of the regulatory authority and/or agency in charge of the planning and coordination mechanisms. Maximum independence from policy makers, as well as the ability to resist potential capture by vested interests, is the key.

The experience from Latin America shows that the responsibility for planning has generally been given to the ministry or to an agency which has strong ties with the government. In the UK, the Government decided to confer the delivery function for its Electricity Market Reform (EMR) onto National Grid, owing to the strong synergies with its existing role in the electricity market, which raised a number of questions regarding potential conflicts of interest. National Grid is, for instance, in charge of the planning process to determine how much capacity to procure through the capacity market in order to maintain security of supply. National Grid is also responsible for running auctions for the CFDs for renewables.

Inherent issues of a central planning process

A second issue with hybrid markets featuring a specific planning process for investment is related to the responsibilities and mandate of the organisation doing the central planning, which may provide the central planner with limited access to information and weak incentives to minimise costs for consumers.

Given the potentially damaging consequences of a blackout, planning agencies and system operators have an incentive to err on the side of caution and over-procure generation compared to the socially optimum level. This leads to the risk of system 'gold plating' and over-investment. This issue becomes particularly serious in presence of high presence of VRE since the information asymmetry may make it particularly difficult for the central planner to assess the expected production of wind and solar.

This is one of the criticisms of the Ontario single buyer that has been made recently as, over the last few years, Ontario's retail prices have risen significantly. This is partly due to the fact that, consumers have to pay for large amounts of new capacity (much of which is conventional) contracted by OPA, despite the falling demand for electricity. The additional contracted-in generation has led to prices rising significantly, with the reserve margin reaching 48% in 2012.

This may imply that the single buyer model tends to put too much investment risk on the consumer, as compared to a more market-based mechanism where private investors would absorb much of the planning risk, if not all the risk. In the case of Ontario, the planning risk faced by the single buyer could have been particularly high because its objective was to induce a large investment which would replace the coal plants that Ontario has committed to phase out.

However, the planning process does not necessarily have to be centralised and this can go some way towards addressing some of the sources of planning inefficiency. Planning can be moved to the level of individual suppliers, who may have more accurate information than the central planner on the forecasted demand of its customers. In this case, the planning at the national level can still be done to monitor the performance of the electricity sector on critical policy variables (e.g. costs to consumers, environmental protection, and security of supply). National or state Integrated Resource Planning processes such as these can inform policy development in structuring and regulating the competitive electric generation market.⁴⁷

⁴⁷ The Tellus Institute (2000).

The experience of Chile, although it highlights the complexities of a decentralised approach, demonstrates that decentralised obligations on suppliers to contract generation in the long term can avoid some of the usual pitfalls of the central planning. In Europe, the French capacity market proceeds with a similar decentralised approach relying on obligations on suppliers.

Table 16 below summarises potential issues and gaps existing in the current hybrid systems with respect to the benchmark market design objectives for integrated resource planning.

Benchmark market design objectives	Potential issues	Gaps / issues in countries surveyed
Efficient resource planning and procurement process	Over / under investment Wrong (costly) technology choices	System 'gold plating' by risk adverse agencies Suboptimal investments increasing costs for consumers
Transparent process for determination of investment needs	Lack of transparency of planning process	Complex / non participative process
Efficient governance and incentives of the planning agency	Lack of independence from policy makers	Capture by vested interests

Table 16: Market design objectives, issues and gaps for integrated resource planning

Source: FTI-CL and Neon

7.4. INTERFACE BETWEEN CENTRALISED AND DECENTRALISED PROCESSES

7.4.1. Benchmark market design

Mandatory risk-sharing instruments introduced in the hybrid prototype should ensure that the short-term operation of power plants is not influenced by long-term supply contracts. If this is not the case, the contracts may prevent owners of power plants from operating them efficiently in the short-run and such inefficient operation may further distort the short-term price signals. Therefore, the benchmark market design objectives for the interface between centralised and decentralised processes may be to:

- Ensure the contracts do not prevent the incentives for efficient short-term operation; and
- Ensure the contracts do not distort the short-term price signals required for flexible resources.

This would require the long-term supply contracts to remunerate capacity independently of the revenues obtained by generators in energy and ancillary services markets and avoid rolling these short-term products into the state-led contracts.

7.4.2. Bridging the gaps

The international experience with hybrid markets shows that one of the key difficulties lies in designing an efficient interface between the long term planning and tendering processes on the one hand and the short term market signals on the other.

The definition of the product that is contracted for under long term contracts is critical to ensure that the operational incentives of market participants are not affected. It is important, for instance, that contracts do not distort the incentives of generators to offer the energy in the short-term markets they would have otherwise in the absence of the contract. As a result, such contracts would not distort the short-term

price signals required for efficient operation of flexibility resources. More generally, distortions of short term energy market dynamics should be avoided.

Examples of such distortions include capacity remuneration mechanisms that link the capacity payments to the energy production. This induces generators to bid below marginal cost so as to increase production, which increases the revenues obtained from capacity payments. This may result in energy prices below economically efficient levels, requiring even larger capacity payments. Such issues were documented, for example, in early capacity payment mechanisms in Argentina⁴⁸ and Spain.⁴⁹ The new capacity market in the UK has been also criticised for linking the capacity product to delivery of energy.

Another example of distortions can be found in the contracts provided to the clean energy in the context of renewable support. For example, the renewable support mechanisms, such as feed-in tariffs (“FIT”),⁵⁰ may create incentives for bidding below the variable cost of production. In the case of VRE, this entails bidding negative prices that would ensure that the energy is cleared in the market and obtains the FIT. Mechanisms based on feed-in premia (“FIP”)⁵¹ limit the negative bidding to the level of the premium and the new CfD contracts introduced in the UK will be set explicitly to dissuade negative bidding by reducing the payment in the event of six consecutive hours of negative prices.⁵²

Ontario, on the other hand, provides a positive example. In Ontario, despite capacity procurement being managed by the single buyer, the mechanism keeps an important role for the dispatch optimisation in the spot market. Generators bid their energy into the spot market run by the Independent Electricity System Operator (IESO) and the spot market clearing mechanism determines the optimal dispatch and the clearing price.

⁴⁸ Oren, S., (2000).

⁴⁹ Fabra, N. and J. Toro, (2005).

⁵⁰ The FIT guarantees that the plant operator would receive the feed-in-tariff price for each MWh it produces. The FIT does not leave the operator exposed to any market risk or to the risk of the imbalance cost or to outages timing risk.

⁵¹ Under a FIP, generators continue to sell electricity into the wholesale market. In addition to the revenues they receive from selling electricity into the wholesale market, the feed-in premium provides a static premium paid to generators.

⁵² Wind Power Monthly (2015)

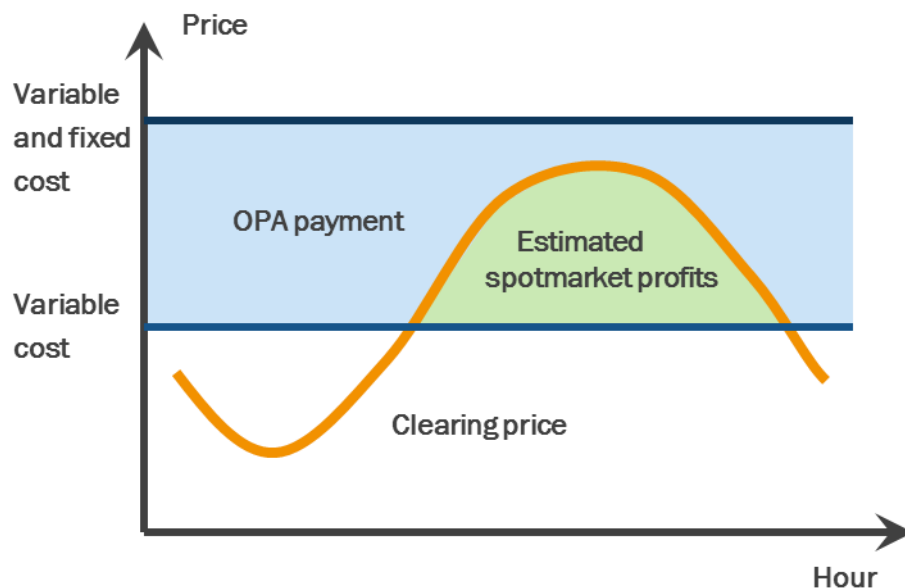

Figure 20: OPA payment to generators

Source: Adapted by FTI-CL Energy based on Castalia Strategic Advisors (2013).

Payments eventually received by generators are based both on the long-term contracts struck with the OPA and the revenues received in the spot market. In particular, the OPA contracts are structured to cover the fixed cost of the generator net of the spot market profits calculated based on the short term marginal cost reported by the generator.⁵³ The payments provided by OPA are illustrated in Figure 20.

The OPA payment determined this way provides incentives for a generator to make capacity available and to systematically bid into the spot market. The mechanism also induces generators to reduce their marginal cost as this allows them to increase their spot market profits. In this sense, the Ontario mechanism induces generators to behave efficiently in the short-run.⁵⁴

However, asymmetry of information between the generator and OPA may induce generators to over-state the marginal costs that OPA uses in the calculation of the payment, which could further increase the cost of capacity procurement under the single buyer mechanism.

⁵³ However, in case the spot market revenues exceed the total revenue requirements, generators are only allowed to keep 5% of this excess, to ensure firms do not receive windfall profits.

⁵⁴ This mechanism is different from the CfD introduced in the UK for the renewable support under the Electricity Market Reform. Unlike the Ontario mechanism, the CfD provides little incentive to bid the marginal cost in the spot market and generally incentivises generators to bid zero or even negative price to ensure the generators produce at all times. Thus, the Ontario mechanism provides better short term efficiency than CfD in the UK.

Benchmark market design elements	Potential issues	Gaps / issues in countries surveyed
Ensure the contracts do not prevent the incentives for efficient short-term operation	Inefficient operational incentives introduced by contracts	Market bids and short-term plant operation inconsistent with plant economics
Ensure the state driven processes do not distort the short-term price signals required for flexibility resources	Product definition may interfere with energy delivery	Distortions of short term energy market dynamics

Table 17: Market design objectives, issues and gaps for interface between centralised and decentralised processes

Source: FTI-CL and Neon

7.5. ORGANISATION OF MANDATORY RISK HEDGING INSTRUMENTS

7.5.1. Benchmark market design

Mandatory risk-hedging instruments introduced in the hybrid prototype often take the form of long-term contracts led by the state requirements supporting investment in generation capacity. These contracts need to be structured and procured in a way that efficiently induces the volume of VRE consistent with the social cost of emission to the society. The state-led contracts (or the contracts awarded in the capacity markets) should also ensure that, for each technology, they reward the specific value that this technology provides to the system, given that contracts cannot be infinitely complex.

The efficiency of contract procurement can be achieved through an auctioning process that is non-discriminatory across technologies and market participants.

The state-led contracts tend to reduce the investment risk, potentially at the expense of transferring this risk to the customer. The state-led contract should be designed so as to achieve an efficient risk sharing between customers and the utility. The efficient sharing of the risk can be achieved by designating the contract counterparty that is best placed to bear the risk.

The benchmark market design objectives for the organisation of mandatory risk hedging instruments can be summarised as follows:

- Induce efficient investment across all types of capacity;
- Transparent and non-discriminatory process for tendering and allocation to third parties; and
- Allow coordinating the investment in generation with the existing and future transmission and distribution networks.

7.5.2. Bridging the gaps

The international experience with hybrid markets shows that one of the key issues in designing efficient long term contracts to support investment lies in the design of the procurement process used to award long term contracts.

A key issue for procurement is related to the general investment planning and is related to the access to information and the information asymmetry between market participants and the authority in charge of system planning and procurement about the costs of various technologies. Efficiency of the procurement process hinges on the ability of the planning agency to get access to accurate information about these

costs. This requires the use of information revealing mechanisms, such as auctions. While auctions allow revealing information and centralise competition, they may allow too high a level of intervention by the procurement agency. Below we discuss the issues around the existing auction processes and the possible decentralisation of the procurement process.

Procurement through auctions

A benchmark auction and procurement design should lead to a fair, open, transparent, objective, non-discriminatory, and timely process. It should incorporate an efficient price discovery mechanism while minimising information and transaction costs. It should lead to an outcome in which bidders that can provide a product at the lowest cost will win, thereby ensuring the optimal use of resources. Lastly, it should minimise the likelihood of challenges to the selection process and outcome, avoiding post-auction delays.

In practice, the international review shows that there is no “one-size-fits all” solution to auction design, and most countries are still experimenting and gradually improving their procurement processes. The main trade-off in the design of auction mechanisms for the procurement of long term contracts is the choice between technology-neutral and technology-specific auctions.

Technology-neutral auctions entitle any generation source to participate in the tender on a level-playing-field basis. The idea is to foster maximum competition, select the most efficient sources and achieve a lowest-cost expansion plan. However, it is often difficult for non-conventional renewable sources to compete head to head with base load coal or large hydro, except under special circumstances. Furthermore, governments may prefer particular technologies due to energy policy concerns or economic policy considerations. Governments could prefer to establish auctions that target one or more types of technologies. The auctions may also combine or distinguish between existing and new capacity: the objectives of seasonal diversification and decarbonisation of the energy mix may favour technology-specific and new/old specific auctions, which ensures head-to-head competition and achievement of the EU RES target.

Another auction design choice is between single and sequential auctions. The high transaction costs of bidding and competing favours single auctions, which bring more bidders to the table and limit the market power of large-scale suppliers. However, uncertainty about the product being auctioned and the bidders’ risk aversion favours sequential auctions, with a small auctioned volume to limit long term price risk.

In Brazil, new renewable capacity is procured through the same procurement auctions as the thermal capacity. This creates a level playing field between technology types. Figure 21 shows the evolution of auction prices by technology. In recent years, wind and hydro plants have been procured at competitive prices with thermal technologies.

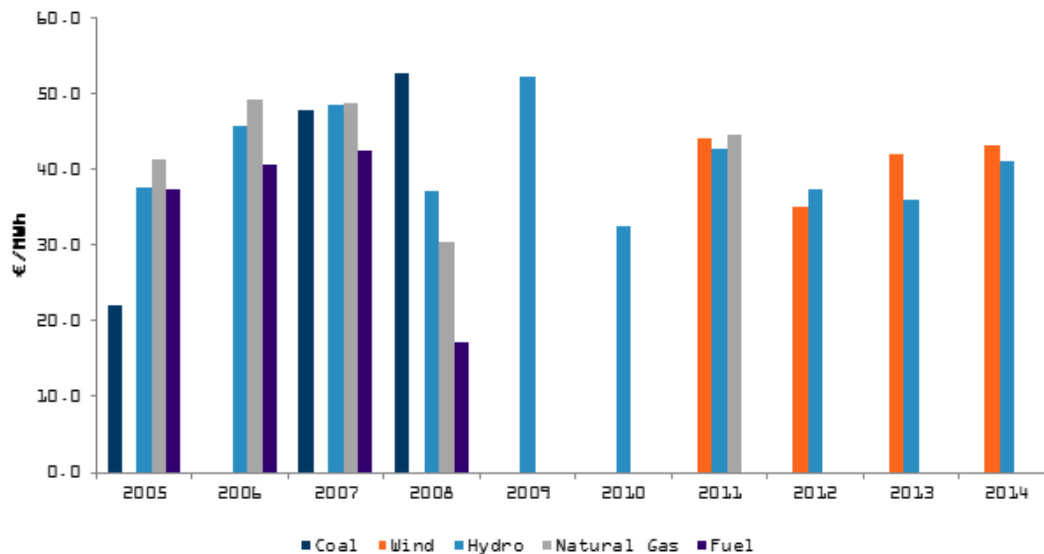

Figure 21: Brazilian auction prices by technology

Source: CEER

Although the procurement through a ‘technology neutral’ approach has many advantages, it leads to a range of implementation issues as different generation technologies provide power with a different level of ‘firmness’ to the electricity system. For instance, competition between technologies may require applying de-rating factors to the installed capacity, which represents a percentage of the installed capacity to estimate that is considered firm. The level of de-rating of variable renewable energy is the subject of fierce debate as critics consider it too favourable to renewable sources.

Centralised and decentralised procurement

A centralised procurement through an auction process raises issues regarding the independence and mandate of the planning and procurement agencies that oversee the process. For instance, in Brazil, there are concerns about potential policy interventions to reduce short term prices by intervening in existing capacity auctions. In addition, the government has chosen to hold three project-specific auctions to develop large hydro investments. They may also hold reserve energy auctions as they wish, and those that have been held have been aimed at developing non-conventional renewable energy developments.

However, at the same time, the centralised procurement through auction process fosters both competition and liquidity, allowing distributors to share the benefits of lower prices. This is particularly the case in the smaller auctions, which are unlikely to draw the attention of larger generation companies.

In Chile, as in Brazil, regulated consumers are required to acquire their energy needs through auctions, and their energy demand must be wholly contracted, for at least three years. However, unlike Brazil, there is no centralisation of generation adequacy assessment and the procurement process. There is no requirement to provide firm energy certificates, and distribution companies themselves must assess the adequacy of a generation companies bid. Distribution companies are then responsible for organising their own procurement processes (while each individual procurement process may also feature auctions for various contracts).

The result of this decentralisation is that no contract is standardised. Auctions can be held at any time and with any design, while contracts can be tailored to meet the specific needs of different distributors.

Where multiple contracts are on offer in an auction, generation companies can bid a net amount greater than their capacity in order to promote competition. Capacity constraints are considered after bidding, so as to achieve a feasible outcome.

All auction designs and final contracts must be approved by regulators and, before an auction, the regulator publicly sets capacity price caps for each auction. Furthermore, to ensure system adequacy, generation companies must give a yearly justification to the regulator that they have sufficient firm capacity to supply all their contracted demand.

Benchmark market design elements	Potential issues	Gaps / issues in countries surveyed
Induce efficient investment across all types of capacity	Information asymmetry between planning agency and market participants	Lack of accurate cost estimates of different technologies Auction design not optimised to reveal information
Transparent and non-discriminatory process for tendering and allocation to third parties	Efficient and transparent procurement process	Need for tailored procurement and auction design to system characteristics
Allow coordinating the investment in generation with the existing and future transmission and distribution networks	Lack of locational signals Lack of integrated planning approach between network and generation / demand	Lack of integrated planning and /or procurement approach

Table 18: Market design objectives, issues and gaps for organisation of mandatory risk-hedging instruments

Source: FTI-CL and Neon

8. PROSUMER MARKET

8.1. INTRODUCTION

We define a *prosumer market* as a power system in which a significant share of generators is located with consumers. These could be households, services, or industry that produce and consume electricity on site. Prosumers exist at large scale (industry) to very small scale (households). Household and service sector prosumers are typically connected to the low- or medium-voltage distribution grids and are small in size (starting from single-digit kW) and hence large in absolute numbers. As a result, generation is decentralised and owner structure is scattered. Three recent IEA-RETD studies (2014, 2015, 2016) provide data and discuss solar PV prosumers in great depth. The prosumer market can co-exist with the wholesale market organised as an energy-only market, as a hybrid market, or as a vertically integrated utility. In this sense, prosumers are a cross-cutting topic in this study.

Prosumers engage in “auto-generation” or “self-consumption” of electricity. Due to their small size, they are often associated with “decentralised” or “distributed” generation. They are a heterogeneous group, comprising mostly three broad types of technologies: (i) small- to medium scale solar PV, mostly owned by the household, service, and agricultural sectors; (ii) small- to medium scale biomass- or gas-fired micro-combined heat and power (CHP) plants, mostly owned by households and agriculture; and (iii) natural gas- or coal-fired CHP plants, mostly owned by industry. In some regions, industry consumers operate wind farms for self-consumption. Prosumers are not synonymous to VRE: they use both VRE and non-VRE technologies; and VRE technologies can be employed by prosumers and other generators.

In traditional power systems, auto-generation was restricted to large-scale industry. Household-level decentralised generation was largely absent. During the past decade, small-scale prosumers emerged in a number of jurisdictions in significant numbers, including Germany, Australia, Denmark and California.

Auto-generation raises a number of questions regarding power market design, which we will discuss in this section. Most of these issues apply not only to prosumers, but to demand-side participation in general and to energy efficiency investments. Most of the market design related to prosumers has implications beyond prosumers.

Prosumers might help reaching different policy objectives including a broad distribution of benefits and costs, increasing acceptance by dispersing ownership, and “democratization” of power generation (IEA-RETD 2014). In this study, we focus more narrowly on power systems effects and the implication of these for the design of power markets.

8.1.1. Case study: prosumer development in Germany

Household-level auto-generation has developed quite recently. In Germany small-scale solar PV auto-generation remains a niche. During the years of fast growth, small-scale (<10 kWp) solar PV represented not more than 10-20% of installed capacity (Figure 22) – and not (nearly) all of this is self-consumed. BDEW (2015) estimates that in 2012, the last year where data are available, 0.5% of household electricity consumption was produced by solar PV auto-generation. Household-level auto-generation represent about 3% of total solar power generation in Germany. However, both types of prosumer generation, by households as well as industry, have been rising steeply in recent years

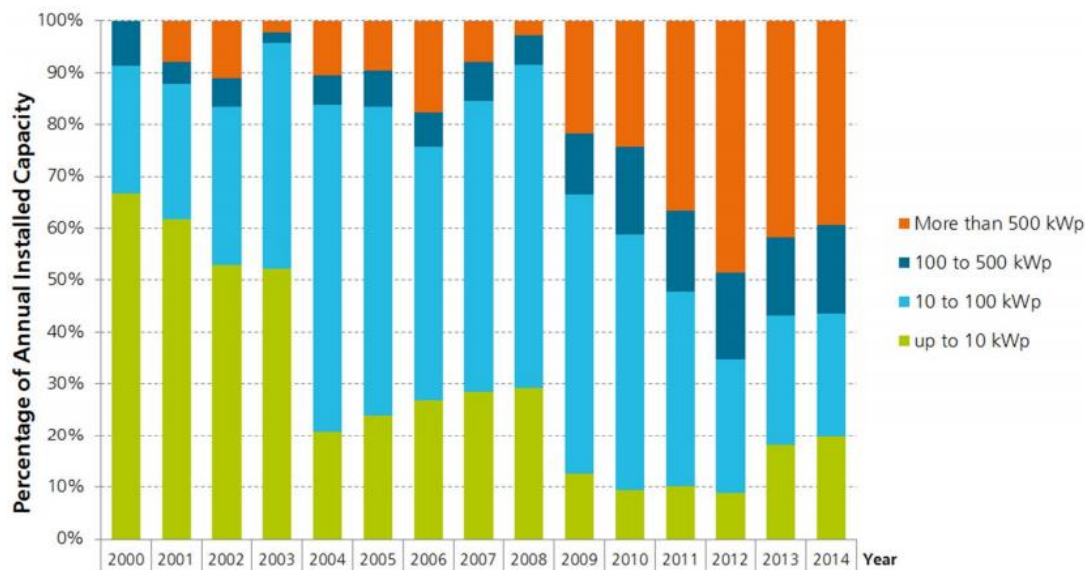

Figure 22: The composition of solar PV installations in Germany by size

Source: Fraunhofer ISE (2015).

In contrast, industrial auto-generation has always been there: in the early 1990s, German industry generated about 20% of its electricity consumption on site, usually from coal-fired plants. As power prices fell with liberalization, the incentives for auto-generation declined and the share of auto-generation in industry fell to 6% in 2005. Since then it has recovered, reaching 12% in 2013, the last year where data are available (Figure 23).

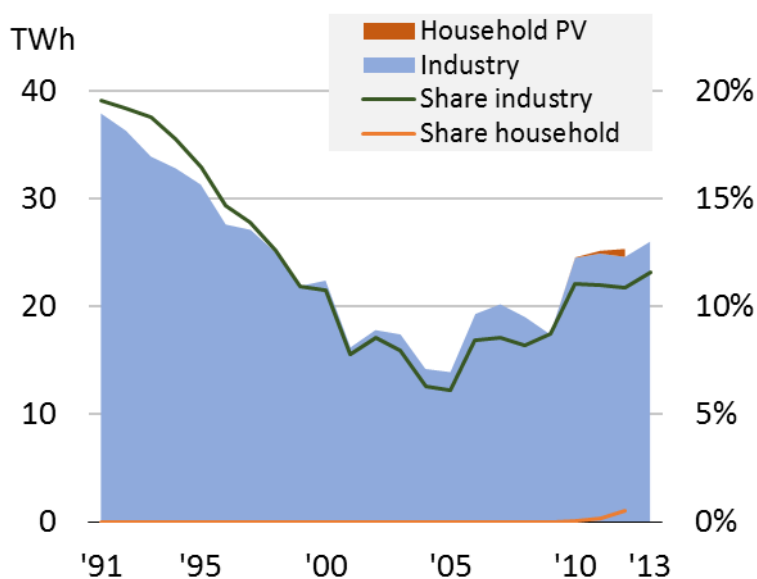

Figure 23: Auto-generation in Germany: industrial and household.

Source: FTI CL Energy and Neon, based on data from various sources including BDEW (2015).

Note: Industrial auto-generation (all fuels) and household auto-generation (solar PV only) in Germany during the past 25 years.

8.1.2. Case study: prosumer development on other selected markets

The steep rise of solar PV auto-generation (despite the low level) has triggered public policy debates not only in Germany, but in a number of jurisdictions, including Australia (Sandiford et al. 2015) and California.⁵⁵

In Australia, by the end of the planning year 2014-15, about 3.7 GW of small-scale solar PV (<10 kW) were installed.⁵⁶ This corresponds to 160 W per capita. To compare, Germany has about 6 GW small-scale PV installed⁵⁷, corresponding to 75 W per capita. Moreover, where Australian solar capacity factors are close to 20%, German capacity factors are around 11%. In other words, Australians generate nearly 4 times more electricity per capita from small-scale solar PV than Germany.

8.2. CRITICAL ELEMENTS OF MARKET DESIGN IN PROSUMER MARKETS

We see four elements of market design that become relevant in prosumer markets:⁵⁸

- **Retail pricing and metering rules.** Consumers make consumption and investment decisions based on price signals they receive through retail electricity tariffs, rather than wholesale electricity prices. The effective price received for self-consumed electricity depends on the level and structure of retail prices and on the way consumption is measured (net metering, or not). The fact that the retail price provides the investment signal for prosumers can be problematic for three reasons: investment incentives might be distorted vis-à-vis non-prosumer investments; prices might fail to signal system needs; and the income of governments and system operators might decline.
- **Regulation of distribution network operators (DSOs).** Small-scale prosumers are typically connected at low voltage levels to the distribution grid. Auto-generation as well as other demand-side participation in electricity markets often requires upgrading distribution networks. Smart grid technologies can often help to contain costs. A market design challenge emerges, because traditional grid regulation has put little emphasis on (smart) investments.
- **Coordination of distribution grid and generation investments.** An important means to limit distribution grid costs is to coordinate generation and grid investments. This requires some signal to prosumer investors where and where not investment is preferable from a grid perspective. Such signals have traditionally not existed, and developing a mechanism to reflect grid costs appropriately is challenging.
- **Market access and balancing responsibility.** Traditionally, generation companies have accessed wholesale markets such as power exchanges or independent system operators directly. Therefore they maintain trading departments. Obviously, small-scale producers cannot each operate their own trading department. Market access has to be organised through intermediaries, or aggregators. Different challenges arise, including the need to organise low-cost market access, competition among aggregators, and balancing responsibilities to prosumers.

⁵⁵ <http://blogs.berkeley.edu/2015/05/08/is-residential-solar-the-future-of-electricity-generation/>

⁵⁶ NEFR 2015 - Supplementary information for residential and commercial rooftop PV

⁵⁷ Fraunhofer ISE 2015 - Photovoltaics report;

⁵⁸ As mentioned above, prosumers operate within a wholesale electricity market that may have features of an energy-only, a vertically integrated, or a hybrid market prototype. As such, to accommodate high shares of VRE, a prosumer market may require reforms of wholesale market design elements relevant to those prototypes.

We address these prosumer-specific market design elements below one by one. For each of the four elements, we discuss challenges and suggest a “benchmark” market design. Table 19 below summarises the challenges.

Element of market design	Challenge presented by VRE
Retail pricing and metering rules	Investment incentives vis-à-vis large-scale (renewables) investments Incentives aligned with system needs Income base erosion
DSO regulation	Large investments in distribution grids required Unconventional solutions likely to be cost-efficient
Distribution grid coordination	Risk of local “hotspots” that require massive distribution grid investments
Market access	Excessive transaction costs for small prosumers Excessive market access risk Unfair distribution of balancing costs; lack of incentive to improve forecasts

Table 19: Critical elements of the market design in a prosumer market prototype

Source: FTI-CL Energy and NEON

8.3. RETAIL PRICING AND METERING RULES

8.3.1. Benchmark market design

Retail pricing

Prosumers generate and consume electricity on a single site. Distributed resources such as rooftop solar photovoltaics (PV) and storage can be installed behind the meter and be financed by savings on electricity bills. To the extent locally generated electricity replaces grid-delivered power, its opportunity cost (and hence economic value) is determined by the retail price, rather than the wholesale price. Historically, in most power systems the retail price was a mere cost recovery mechanism. In a prosumer market, its role changes: it becomes a price signal for dispatch and investment. This assumes that the retail price is defined as a commodity and not as a service-oriented good, as discussed in Section 4 above.

Retail prices typically comprise the following price components: (i) energy, which corresponds to the wholesale power price; (ii) the retail company’s profit margin; (iii) charges for transmission and distribution grids; (iv) taxes on electricity, if applicable; and (v) levies to finance support schemes for renewables, if applicable.

The current state of retail pricing can be best understood in historical perspective. Retail prices have been traditionally seen as cost recovery mechanisms. It was hard to reduce electricity consumption (in economic jargon, electricity demand was very price-inelastic), which made it a welcome target for taxation. In addition, the desire to incentivise energy conservation motivated some green tax reforms adding further electricity taxes.

Each of these components has a certain structure: it can be a fixed charge (independent of the amount of electricity consumed), a capacity charge (depending on the connection capacity or the capacity that the customer contributes during times of peak demand), or an energy charge (per kWh). Energy costs, taxes, and levies are often energy charges. The structure of grid fees varies significantly by jurisdiction. In some countries, they comprise mostly fixed charges, in others mostly energy charges. Overall, this results in a retail price that is partly fixed, partly capacity-related, and partly energy-related. While the exact

economic drivers depend on rate design, it is frequently the energy-related share of the retail price that provides the strongest incentive to self-consume electricity.

The figures below give examples of the composition of retail prices in Germany (Figure 24) and Australia (Figure 25). While details differ, they share the fact that energy costs comprise only a relatively small share of households' electricity bill. In other words, wholesale and retail prices differ significantly. Moreover, retail prices differ starkly by customer type, both because different consumer types connect at different voltages and because some consumers might be exempted from certain charges. In many OECD countries, energy-intensive industries are exempted from many taxes and fees (see example for Germany below), such that industrial retail prices are much below household prices. In many emerging economies, discrimination is opposite, where household prices are lower. PWC (2015) and Ecofys & Fraunhofer ISI (2015) provide broad and deep data on industrial retail prices.

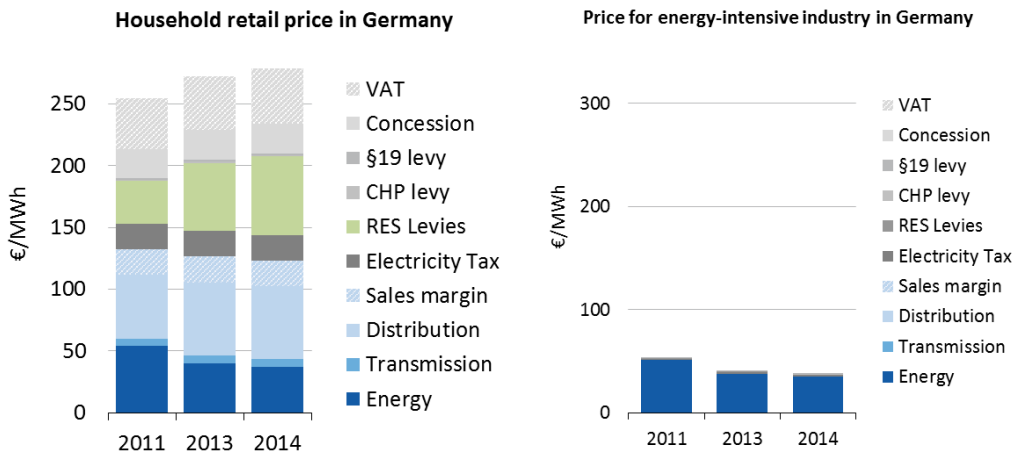

Figure 24: The composition of retail electricity prices in Germany 2011-14 for household (left) and very large energy-intensive industries such as aluminium smelters

Source: FTI CL Energy and Neon.

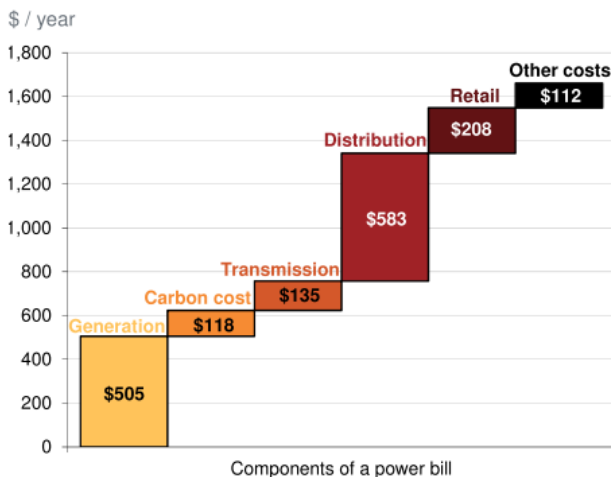

Figure 25: The composition of household electricity bills in Australia

Source: Grattan Institute (2014)

Metering rules

Next to the size and structure of the retail price, a second factor determining the incentives to auto-generate are the metering rules. There are three principle ways how prosumer generation and consumption can be metered: (i) separately with two different meters; (ii) jointly with one meter over short intervals; (iii) jointly over long intervals. The last method has become known as “net metering” (see Table 20).

Metering rule	How it works	Share of produced electricity that is self-consumed	(Implicit) price earned for electricity generated
Net metering	Meter “consumption minus production” over longer time interval (e.g., one year)	High for small-scale systems (often 100%)	Retail price (Wholesale price + grid fees + taxes + levies)
“Real time” net metering	Meter “consumption minus production” over short interval (e.g., one hour)	Without storage: low to moderate (because of mismatch of consumption and production)	Retail price for self-consumed Wholesale price for “excess”
		With storage: moderate to high	Retail price for self-consumed Wholesale price for “excess” Minus costs for storage
Separate metering	Generation and consumption are metered separately (and possibly priced differently)	Zero	Wholesale price + system service revenues

Table 20: Metering rules: how net metering works and related pricing

Note: under support schemes for renewable energy, electricity fed into the grid might be priced at a feed-in-tariff, or the wholesale price plus a feed-in-premium, rather than the wholesale price alone.

Box 1: A simple illustrative example of the implications of retail pricing and metering rules on (implicit) generation incentives for prosumers

Consider a simple example to illustrate the relevance of metering rules. Assume a household consumes 4 MWh (4000 kWh) of electricity per year at a retail price of 30 c/kWh, of which 3 c/kWh is the cost of energy (corresponding to the wholesale price), the rest is comprised by fees, taxes, and levies. Hence the annual electricity bill is EUR 1200. Assume that all components of the electricity bill are paid per kWh, meaning that there are no fix price components. If the household produces 1 MWh of its electricity needs itself, the bill reduces by EUR 300. In other words, each MWh of self-consumed electricity has an economic value of EUR 300 to the household. In contrast, when selling one MWh of electricity to the wholesale market, it earns only 30 €/MWh. This example does not consider revenues from support schemes.

Under separate metering, the revenue would be the wholesale price, 30 €/MWh (assuming that excess is remunerated with the wholesale price). Under net metering, the household would reduce its net yearly consumption to 3 MWh. The (implicit) revenue is the retail price, 300 €/MWh. Under real-time net metering, the household would reduce its electricity consumption by, say, 0.25 MWh, because the rest of generated at times when the household does not consume. The remaining 0.75 MWh is sold at the wholesale price, resulting in a mean revenue of 97.5 €/MWh. If the household installs a battery to improve the match between production and generation, managing to increase self-consumption to 0.5 MWh, mean revenue increases to 165 €/MWh (without considering the costs for the battery).

Metering rule	Share of production that is self-consumed	Average price earned
Net metering	100%	300 €/MWh
“Real time” net metering w/o storage	25%	97.5 €/MWh
“Real time” net metering with storage	50%	165 €/MWh minus cost of storage
Separate metering	0%	30 €/MWh

Table 21: Metering rules: how net metering works and related pricing

Note: under support schemes for renewable energy, electricity fed into the grid might be priced at a feed-in-tariff, or the wholesale price plus a feed-in-premium, rather than the wholesale price alone.

To sum up, the retail price constitutes an incentive to invest and produce for prosumers. The exact incentive depends on (i) the size and structure of the retail price, and (ii) metering rules. Both factors are a matter of market design and can be determined to a large degree by policy.

Benchmark market design

IEA 2016 also stresses the importance of the retail price reform for the future decarbonised electricity market:

“Retail prices should give the right incentives to both network users and distributed energy resources, in a timely and location-specific manner. Development of real-time pricing reflecting local power production should be encouraged to give the right signals to invest and operate distributed resources.”

A benchmark market design should provide fair incentives to prosumers such that investors can take informed decisions that give the best value to society. It should neither overpay nor underpay, but rather establish a level playing field across generation investments of all sizes at all locations. Generators of any size should receive the price that commensurate with the benefits they provide to society, as reflected in the wholesale price and the price of system services. The (explicit or implicit) price that prosumers receive for producing power, if consumed themselves or sold to the market, should equal the price any other generator receives, plus or minus the additional benefits or costs they cause in the power system or society more broadly. If benefits arise, for example through reduced network losses, distribution grid investment deferral, or increased resilience (see IEA-RETD 2014, IREC 2013), these benefits should be allocated to the prosumers. Then prosumers receive a higher price per MWh than other generators. In many cases, however, the additional benefits or costs might be modest (e.g., Borenstein 2008). In this case, auto-generation should receive the same price as market-generation.

Designing a retail price that provides efficient incentives is not a trivial task. It requires a fundamental consideration of the role of taxes. Also, calculating the true value of electricity at every moment in time at every location in the distribution grid faces a strong transaction cost trade-off. Moreover, some of the broader policy objectives (such as increasing acceptance or democratizing energy supply) are likely to be hard to quantify in monetary terms.

When thinking about a benchmark market design in terms of retail pricing and metering rules, three distinct objectives can be identified:

- fair incentives for prosumers compared to other (e.g., large-scale renewables) producers;
- incentives do deliver system needs (e.g., flexibility); and
- addressing the issue of erosion of income base for taxes and grid fees.

We will discuss each topic one by one in the following.

Investment incentives. In many jurisdictions, there is a significant gap between the levels of wholesale and retail prices. Valuing power production with retail prices may misalign investment and production incentives. The underlying reason is that auto-generation is *de facto* exempted from fees, levies, and taxes, it is implicitly subsidised. To the extent this is the case, investors are triggered to build small-scale generators locally, whereas it might be more cost-efficient to build a larger plant elsewhere. Take the illustrative example from the box above: in the extreme case, a small-scale PV investment that has levelised generation costs of 299 €/MWh is profitable from an investor perspective, while a large-scale PV plant with costs of 31 €/MWh is not. For society, of course, building a cheaper PV plant is preferable (assuming that all other characteristics of the plant are identical). A benchmark market design would reward power generators, including prosumers, according to their merit for the power system, regardless of their size.

Flexibility incentives. Valuing power production with retail prices makes it challenging to provide efficient signals for flexibility. For example, even if wholesale prices are negative (a signal that generators should

reduce output), retail prices will usually still be positive, because both of time-invariant pricing and because of time-invariant retail price components. More generally, investment and production incentives should be aligned with system constraints and requirements. A benchmark market design provides such aligned incentives to all generators, including prosumers.

Income base erosion. Another issue that retail pricing and metering should be able to address is the problem of “tax base erosion”, or more precisely: the erosion of the income base for governments and network system operators. This problem arises if grid fees, taxes and levies are calculated based on electricity consumption from the grid on a per-kWh basis. With rising auto-generation, the quantity of grid consumption and hence the base for fees and taxes shrinks. If fees remain unadjusted, the income for governments, TSOs, and DSOs declines. If the revenue ought to remain stable, while being collected from a smaller base, the rate of charges and taxes need to be increased. Higher prices, in turn, further increase the incentives to auto-produce – self-enforcing feedback mechanism.⁵⁹ In economic terms, in the presence of suboptimal network charges and tax design, auto-generation constitutes a negative externality: generating power yourself has a negative impact on other economic actors, as they have to pay more for electricity networks, subsidies, and taxes. Note again that auto-generation shares this property with energy efficiency measures.

To sum up, a benchmark market design (i) rewards prosumers according to the value their production has to the system and to society, (ii) aligns incentives with system constraints and provides incentives for providing flexibility, and (iii) avoids the erosion of government and system operator income. More generally, a benchmark market design rewards generation from prosumers and non-prosumers equally. Prosumers receive a larger price than other generation to the extent that they provide additional benefits to the grid or to society, not for the fact that they are prosumers as such.

8.3.2. Bridge the gap

Coming closer to this market design ideal can be achieved through various design choices of retail pricing and metering. None of them is without disadvantages. Two broad directions of change may be considered to narrow the gap between the price paid to auto- and other generators:

⁵⁹ Commentators have found strong words for this self-enforcing mechanism, including “vicious circle”, “de-solidarization” or even “death spiral” (Grattan Institute 2015)

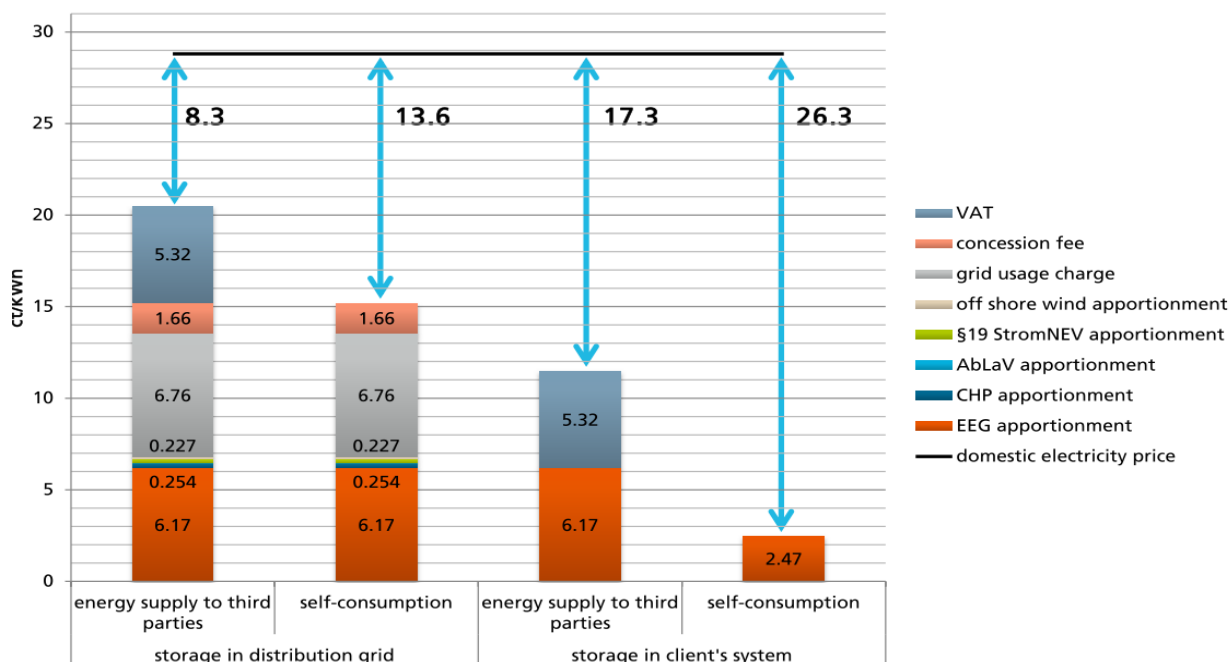

Figure 26: Taxes and fees for an energy storage device in Germany.

Notes: Taxes and fees applied to electricity for different consumers (self or third party) and different locations of an energy storage device (in the grid or at site of the prosumer)

Source: Fraunhofer ISE 2015

- *Option 1: other finance sources.* One option is to free the retail electricity price from its role as a collection mechanism for government and system operator income. In the extreme electricity could be alleviated from all specific taxes and levies. Renewable support schemes and grids could be financed from the general budget, similar to other infrastructure. The retail price declines and the gap to the wholesale price narrows. If such measures are done in isolation, i.e. without increasing wholesale prices, this will reduce the incentive to conserve energy and to invest in energy efficiency. This is seen as problematic by many observers.
- *Option 2: tax all electricity consumed.* A radically different option is to apply taxes, charges, and levies to total consumed electricity, rather than grid consumption. In the extreme, self-consumption would be taxed exactly the same as any other consumption. In principle, this solves both inefficient investment incentives and avoids eroding the tax base. However, there is considerable disagreement if such a taxation of self-consumption is legal or politically feasible. In addition, misaligned flexibility incentives may remain. One way to implementing option 2 is to apply separate metering for production and consumption.

Effectively, option 1 narrows the gap between retail and wholesale prices while allowing consumers to reduce their electricity bill by auto generation; option 2 leaves the gap intact, but closes the possibility to evade paying price components such as taxes and grid charges (see Table 22 below).

Type of pricing and metering	Retail price	Base for taxes, levies, fees	(Implicit) revenue for power generation
Net metering, traditional retail pricing	Wholesale price + grid fees + taxes + levies	Grid consumption	Classical retail price
Benchmark Opt 1: net metering, reformed retail price	Wholesale price + system benefits	Grid consumption	Reformed retail price (= wholesale price + system benefits)
Benchmark Opt 2: separate metering, traditional retail pricing	Wholesale price + grid fees + taxes + levies	Total consumption	Wholesale price + system benefits

Table 22: Two benchmark (but equivalent) benchmark market designs for retail pricing and metering

Source: FTI-CL Energy and NEON

In many ways, auto-generation parallels energy efficiency. If electricity consumption is reduced without reducing peak demand, energy efficiency investments increase the grid costs for other consumers. Similarly, incentives for flexibility might be equally important for demand-side flexibility such as heat pumps or e-mobility.

This is how a transition pathway could look like for each of the two options:

Option 1: other finance sources (reformed retail price)

A transition should be done gradually and according to a pre-announced schedule to avoid disruptive changes. The transition could follow these steps:

- **Transform electricity tax to pollution tax.** Today, many countries charge a specific tax on electricity consumption (distinct from VAT and levies to finance RES support schemes). This tax was sometimes introduced as part of a green tax reform package, to reflect the environmental externalities related to power generation and to provide incentives for energy conservation. The problem is that large-scale plants are taxed (including renewables), while prosumer-generation is not (regardless of being renewable or not). Electricity taxes should be transformed to better reflect their purpose: rather than taxing electricity, the pollution itself should be taxed (NO_x, SO_x, particulate matter, greenhouse gases, noise, biodiversity impact). Renewable generators that lack these externalities are not taxed, regardless of their size. The biased treatment of prosumers vs. non-prosumers disappears. For example, the United States introduced an emission trading scheme for NO_x and SO_x in 2005 (Burtraw & Szambelan 2011). This policy internalises the health harm these pollutants cause.
- **Create level playing field between large scale and decentralised generation.** Explicit support schemes specifically targeted to prosumers, such as support programs for small-scale batteries, should be adjusted to the extent they provide necessary incentives for further technology development and cost reduction without creating distortions that favour prosumer solar PV relative to other solar PV.
- **Adjustment of net metering.** Netting generation and consumption over time spans longer than the schedule interval should be adjusted, e.g. substituted by metering over shorter periods or by separate metering.
- **Clean up the electricity bill by financing RES support from other sources.** Rather than financing RES support schemes from levies on grid consumption, they could be financed from other sources, such as broadening the tax base to other sources of energy, use revenues from emission charging (see above), and /or financing from the general public budget.

- **Reform grid tariffs.** Introduce capacity-based grid fee component (and maybe grid fees for generation, a so-called “G-component”) to finance network costs. If grid tariffs reflect the true cost structure of the network, all generators are treated fairly. Auto-generation receives a higher price than large-scale generation – to the extent it reduces grid losses and network expansion costs. This is economically sensible and provides efficient incentives.

Prosumer support and net metering RE-PROSUMERS and RE-COM-PROSUMERS

Two recent IEA-RETD publications have addressed the issues of prosumer support and net metering in further detail. RE-PROSUMERS suggest three possible pathways:

- **Constraining prosumers**, i.e. actively penalizing prosumer development through the creation of new taxes or fines.
- **Enabling prosumers**, i.e. introducing incentives and favourable interconnection standards.
- **Transition to prosumers**, i.e. supporting prosumer development while at the same time introducing legal and regulatory reforms. Two types of transition approaches are distinguished:
 - Incremental - adjustments to existing policy and regulatory frameworks that attempt to minimise revenue loss in the utility sector or recover transition costs directly from prosumers.
 - Structural - policies that fundamentally alter the structure of the electricity market or utility sector.

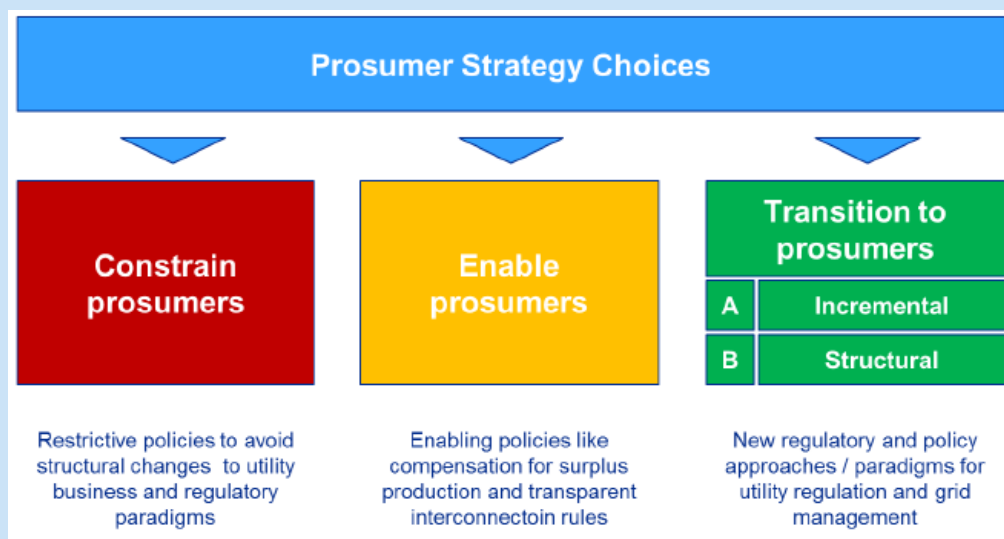

The RE-COM-PROSUMERS publication concludes that targeted interventions from policy makers and stakeholders aimed at enabling a sustainable growth of commercial prosumers could include among other things designing clear policies for net excess generation. This concerns rules governing the treatment of excess generation to enable commercial prosumers to export excess generation during times of low demand.

For markets where commercial retail rates are below LCOE of PV, any rate offered for excess generation would likely need to be designed as slight premium to the commercial retail rate paid in order to drive adoption.

For markets where commercial retail rates are above LCOE of PV, the rate offered for excess generation would likely need to be below the retail rate paid, in order to avoid excess compensation and encourage efficient use.

Table 23 summarises these individual reform options.

Market design element	Goal
Transform electricity tax to pollution tax	Fair incentives for clean electricity generation
Adjust prosumer-specific support	Avoid distortion of investment incentives vis-à-vis large-scale (renewables) investments
Adjustment of net metering	Avoid (wrong) incentive to match local consumption and production rather than provide flexibility to the grid (match system-wide consumption and production)
Finance RES support from other sources	Avoid distortion of investment incentives vis-à-vis large-scale (renewables) investments
Reform grid tariffs	Make grid tariffs reflect the true cost structure of the network; incentivise peak reduction

Table 23: Benchmark market design elements and potential issues – retail pricing and metering rules (Option 2)

Source: FTI-CL Energy and NEON

The structure of distribution grid tariffs are very heterogeneous, even within Europe. As Figure 27 shows, the share of fixed charges in total revenues ranges from below 30% to above 80%.

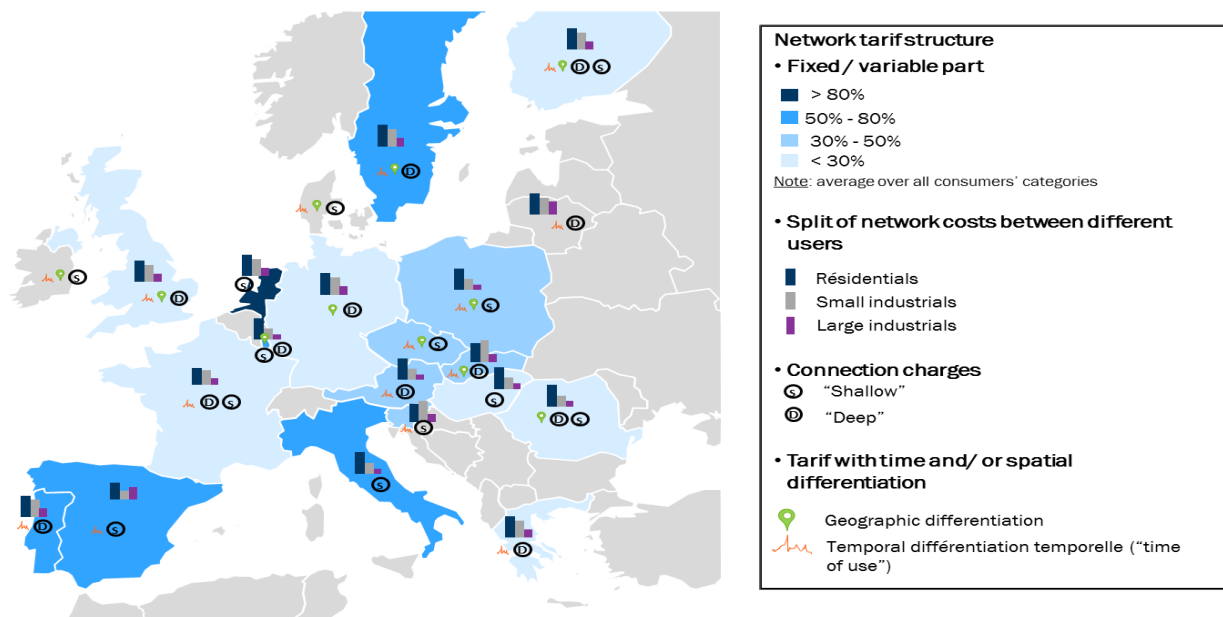

Figure 27: Benchmark of European distribution network tariffs

Source: FTI CL Energy based on data from European Commission (2015), "Study on tariff design for distribution systems"

On the last issue, a reform of the structure of network charges, a lively public policy discussion is under the way in all jurisdictions studied. A number of TSOs and DSOs suggest increasing the role of capacity (as opposed to energy) payments in network fees. Industrial prosumers (VIK 2015) demand that supply of system services such as balancing power should be exempted from grid fees; currently they are not – such that prosumers refrain from providing such services to avoid increasing their peak load and hence higher network capacity charges. In the state of New York, the Department of Public Service (2014) recommends that tariff rates should reflect the costs and constraints of the power system. Pérez-Arriaga & Bharatkumar (2014) provide a proposal on how to allocate to network users according to network utilization profiles

that capture each user’s contribution to total system costs. Figure 28 suggests that switching from energy to capacity charges for grid fees helps to reflect the true price structure of electricity grids better. However, a larger share of capacity-based payments has trade-offs with other policy objectives, including regressive effects on poor households and reduced incentives for energy conservation.

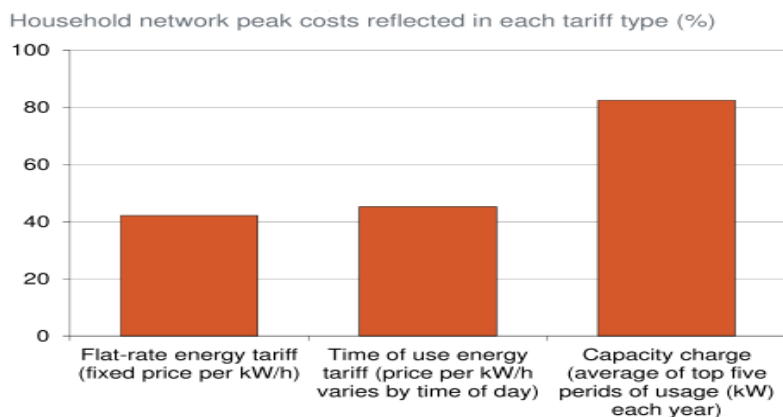

Figure 28: The share of network peak costs “seen” by households under different tariff schemes (Australia)

Notes: The share of network peak costs that is reflected in different types of grid tariffs. Estimates based on data from Victoria, Australia.

Source: Grattan Institute (2014)

Benchmark market design elements	Potential issues	Gaps / issues in countries surveyed
Transform electricity tax to pollution tax	Incentives for dirty electricity generation	Emission trading scheme for SO _x and NO _x implemented in the United States; CO ₂ emission trading scheme implemented in the European Union; lack of comprehensive pollution pricing in virtually all jurisdictions
Adjust prosumer-specific support	Distortion of investment incentives vis-à-vis large-scale (renewables) investments	Specific support continues to exist, e.g. subsidies for “solar batteries” in Germany
Adjustment of net metering	Avoid (wrong) incentive to match local consumption and production rather than provide flexibility to the grid (match system-wide consumption and production)	Net metering scrutinised almost everywhere, but still in place in many jurisdictions
Finance RES support from other sources	Distortion of investment incentives vis-à-vis large-scale (renewables) investments	Some countries finance RES support scheme from general budget (e.g., The Netherlands)
Reform grid tariffs	Grid tariffs do not reflect the true cost structure of the network; peak reduction not incentivised	Public policy discussion in all jurisdictions surveyed (California, Australia, New York, Germany), but many difficulties and problems in implementation; concerns about effect on poor households and about reduced energy conservation incentive

Table 24: Benchmark market design elements and gaps – Retail pricing and net metering (option 1)

Source: FTI-CL Energy and NEON

Option 2: tax all electricity consumed (tax all types of electricity consumption equally)

To level the playing field across generator sizes, another option is to apply taxes and levies to *all electricity consumed* – regardless if it is auto-produced or grid-delivered. Taxes and fees should be applied according to economic principles. That means, not all components are identical: grid fees, for example, should be applied only to the extent to which grids are actually used (autarkic prosumers that are not connected to the network might not pay any grid fees). Taxing total consumption as opposed to grid consumption requires, of course, metering what is locally produced, which raises legal and practical concerns. To avoid disruption, a smooth transition could follow these steps:

- **Industrial prosumers.** Introduce gradual taxes, levies and fees to newly installed prosumer assets of large prosumers, such as industry (> 10 MW).
- **Service prosumers.** Introduce gradual taxes, levies and fees to newly installed prosumer assets of medium-sized prosumers, such as the service sector (> 100 kW).
- **Household prosumers.** Introduce gradual taxes, levies and fees to newly installed prosumer assets of small prosumers, such as households (< 100 kW).
- **Alternative: proxy-taxation.** To reduce transaction costs such as metering and monitoring for small-scale prosumers, the generation asset itself rather than the electricity produced could be taxed. These taxes should be earmarked, and parts of them should go to system operators.

Figure 29 summarises the two proposed options for retail pricing and metering as an indicative transition pathway over time.

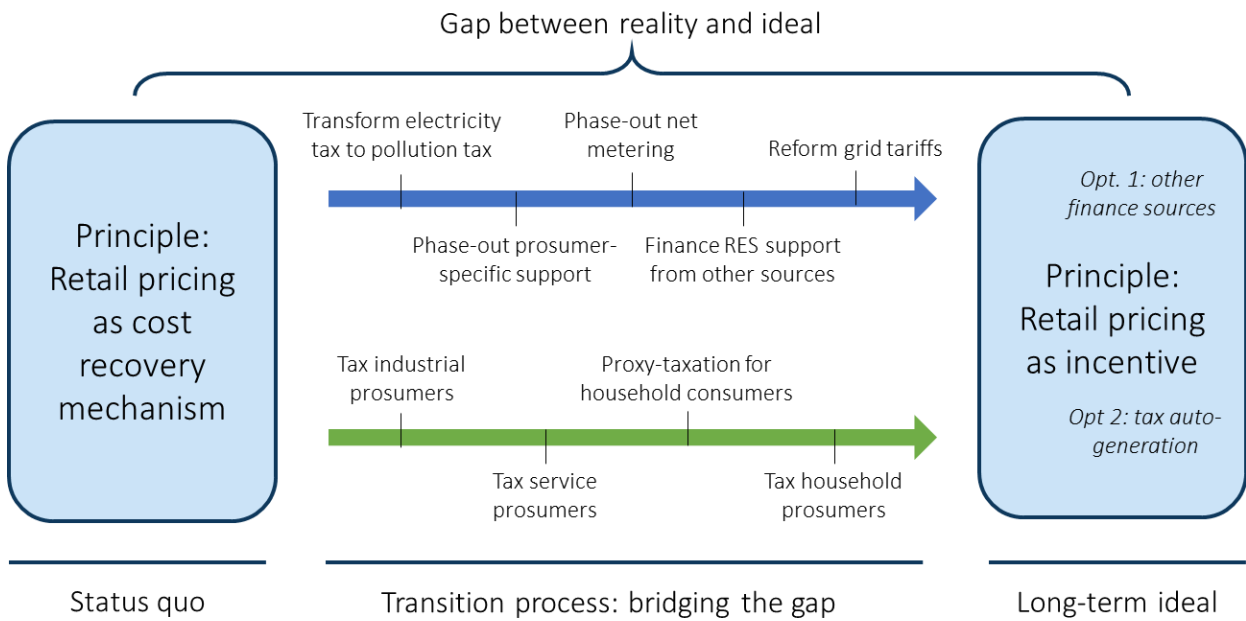

Figure 29: Two transition pathways for prosumer market design

Notes: Two potential pathways to establish fair incentives for auto-generation.

Source: FTI-CL Energy and NEON

8.4. REGULATION OF DISTRIBUTION NETWORK OPERATORS (DSOS)

Small-scale prosumers are typically connected at low voltage levels to the distribution grid. Small-scale generation as well as other demand-side participation in electricity markets often requires upgrading distribution networks. Figure 30 presents a summary of estimates of upcoming distribution grid investment costs in the next 15 years in the case of Germany, ranging from € 20bn to € 35bn.

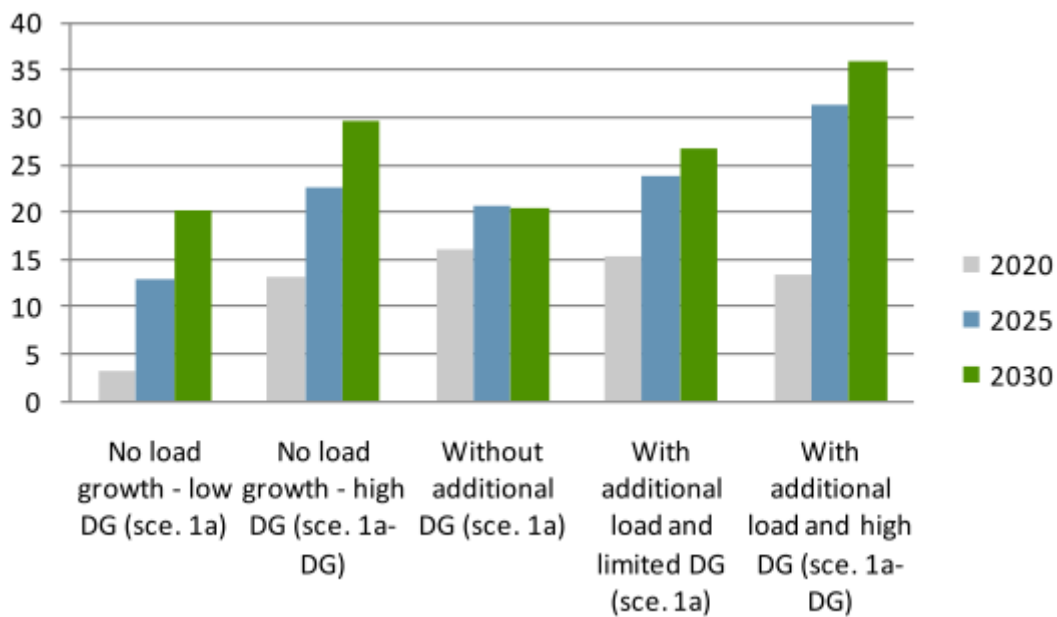

Figure 30: Upcoming investment costs for distribution grids in Germany

Notes: Estimates of cumulative distribution reinforcement costs in Germany under different assumptions of distributed generation (DG) and load growth.

Source: Imperial College et al. 2014

8.4.1. Benchmark market design

Regulation of the distribution networks should be modified in order to induce investment in the network that is consistent with the prosumer market.

On the one hand, a regulatory approach is required that is able to incentivise the large scale of investment that is needed. On the other hand, a benchmark regulatory approach should incentivise *efficient* investments, particularly new planning approaches and smart grids. For example, unlike the traditional approach to grid expansion where full nameplate capacity of a new plant is connected and associated network expansion is made, it might be sensible to connect solar PV plants at 60% or 70%, rather than 100%, of peak capacity. This would allow reducing costs greatly without major risk of network overload.

Unconventional distribution network planning and smart grid technologies can reduce total network costs significantly (see Figure 31 below).

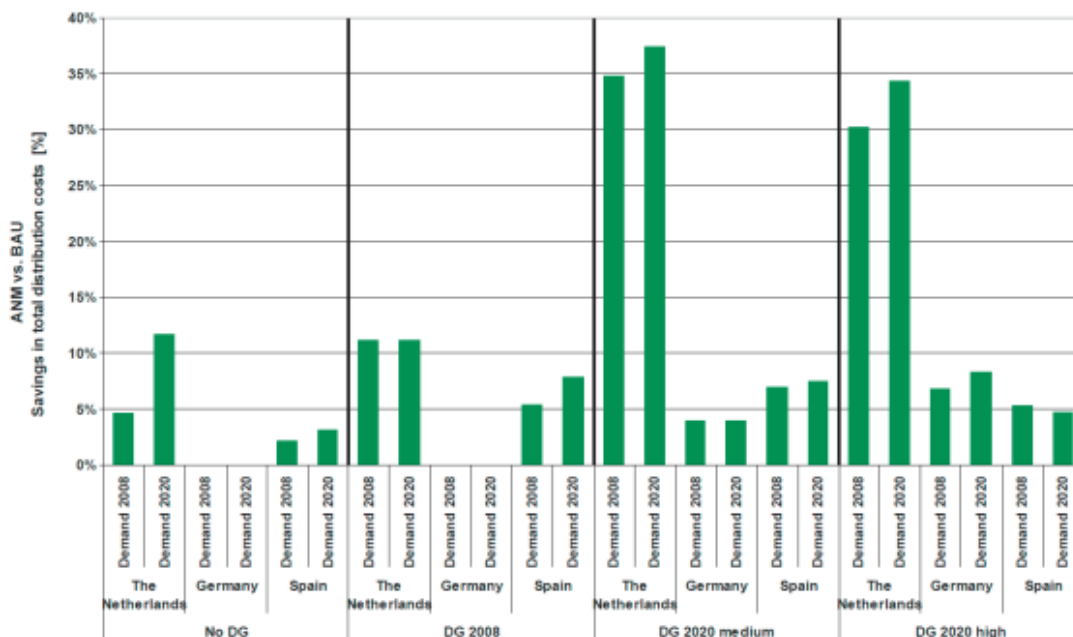

Figure 31: Savings in total distribution costs from active system management for The Netherlands, Germany, and Spain

Notes: Smart system management can save up to a third of total distribution costs, according to one estimate. The scenarios are differentiated by the amount of decentralised generation (DG), of which a significant share is likely to be prosumers. High DG development greatly increases distribution costs, but also opens the possibility to save much of these costs if smart active grid management is applied.

Source: Cossent (2013)

Depending on the incentives for demand response, it can increase distribution grid investment needs (if it responds to wholesale price signals that lead to an increase of local power flows) or it can decrease investment needs (if it used to reduce local power flows). In a major study for the European Commission (Integration of Renewable Energy in Europe), Imperial Colleague et al. have estimated the economic benefits of demand response. The lion’s share of benefits occurs in the distribution grid (Figure 32).

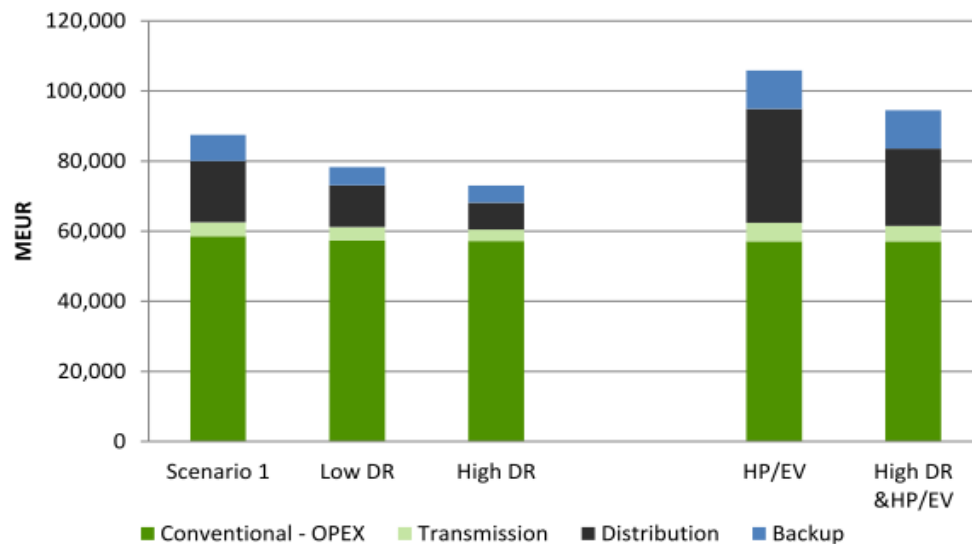

Figure 32: Demand response can save up to € 35bn in European distribution grids

Notes: Economic benefits of demand response. A significant share of benefits occur in the distribution grid. The study covers all EU member states and runs until 2030.

Source: Imperial College et al. 2014

A benchmark regulatory framework for DSOs in the presence of very high shares of VRE should focus on output (service, quality, reliability) rather than inputs (costs) in order to provide the right incentives.

A benchmark regulatory framework for DSOs should also focus on innovation, acknowledging the fact that smart distribution grids are likely to be much more cost-efficient on the long term, but innovation is risky and might fail. A benchmark regulatory framework hence incorporates non-traditional forms of distribution network investments, such as smart grids and network storage.

Massive distributed generation, by prosumers or not, requires upgrades of the distribution grid. Investments in conventional and “smart” technologies are needed at a scale not seen in decades in the stagnating electricity markets of Europe. The regulatory framework of cost-plus or incentive regulation employed in the past decades is better equipped to incentivise efficient operation of existing assets than to incentivise larger-scale investments efficiently.⁶⁰

8.4.2. Bridging the gap

Great Britain, where many amendments to grid regulation have been implemented in recent years, might offer a number of lessons learned for its peers. British regulator Ofgem has introduced the performance-based RIIO framework to regulate electricity (and gas) transmission and distribution companies. RIIO stands for “revenue = incentives + innovation + outputs”. It is a regulatory framework that rests on the idea of output/performance-based, rather than input/cost-based, regulation. It is the quality of network operation, not the cost base that determines the price grid operators can charge. Moreover, the RIIO

⁶⁰ Arín (2013) and Jenkins & Pérez-Arriaga (2014) provide in-depth reviews, THINK (2013) an accessible policy paper. The New York State Department of Public Service (2014) provides an analysis of the New York experience.

framework provides specific incentives for investments in innovative and smart electricity grids. Italy is another country that introduced changes in its regulatory framework specifically to foster innovations.⁶¹

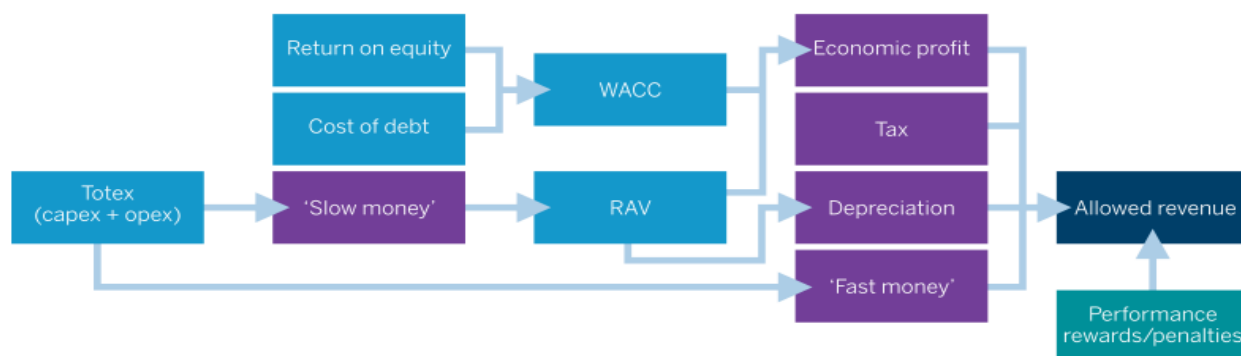

Figure 33: Ofgem’s RIIO framework

Notes: The RIIO-ED1 price control sets allowed revenues for the 14 electricity DNOs over the eight year period 1 April 2015 to 31 March 2023. The chart summarises the key elements of Ofgem’s framework.

Source: FTI CL Energy

Other markets that have been growing dynamically, including most emerging economies, might have already a regulatory framework in place that is more targeted on investments.

Benchmark market design elements	Potential issues	Gaps / issues in countries surveyed
Incentives for large-scale investments	Efficient investment across network and generation	Sluggish investments discussed in many countries, curtailment of VRE generation due to distribution net constraints in several markets
Smart grid solution incentivised	Project risk insufficiently acknowledged in regulatory framework; Incentivise innovation	Traditional regulatory frameworks do not offer specific incentives for (risky) unconventional technology
Output-oriented regulation	Suboptimal incentives of input-oriented regulation	Output-oriented regulation of DSOs is being pioneered by the UK; public policy debate under the way in Germany

Table 25: Benchmark market design elements and gaps – DSO regulation

Source: FTI-CL Energy and NEON

8.5. COORDINATION OF DISTRIBUTION GRID AND GENERATION INVESTMENTS

Planning and operation of distribution grids in prosumer markets is challenging because significant amounts of electricity are generated at low voltage levels. In traditional power systems, almost all power plants are connected to transmission grids; distribution networks used to be one-way channels. At low penetration rates of small-scale solar PV, such as a few percent of annual electricity consumption, this has

⁶¹ See Benedettini et al. (2012) for a comparison of the Italian and British reforms and IEA (2016) for further discussion of DSO regulation.

no significant impact on the need to upgrade distribution grid infrastructure. But at higher penetration rates, significant distribution grid investments are required.

With higher shares of small-scale generation, distribution grids become two-way channels. In principle, electricity infrastructure is agnostic about the direction of power flow: underground cables, overhead lines, and transformers can be used in “either direction”.

8.5.1. Benchmark market design

A benchmark market design for distribution networks reflects both the existing constraints in distribution grids and the costs of grid expansion. These constraints are signalled to decentralised generators as price signals such as grid connection or grid usage fees, such that they are accounted for in the investment decision. In this way, investment in the grid and investment for new generation should be coordinated. Hence a benchmark design avoids two problems

- Excessive costs for distribution grid upgrades in VRE hotspots where VRE development happens in a very concentrated manner
- Location of VRE generation at locations where generation is cheapest, rather than at locations where the benefits (for the grid) are greatest

8.5.2. Bridging the gap

Currently there is often a ‘build and connect’ approach which means that the trade-offs are not adequately taken into account.

Traditionally, distribution grids are sized to be able to deliver expected joint peak demand of connected consumers, plus some safety margin. Grids follow consumers in the sense that distribution networks are upgraded if new consumers appear.

At higher penetration rates, distribution grid investments are required. Solar generation within a distribution grid, however, is highly correlated – much more than consumption: it is likely that in a sunny summer noon, nearly all solar generators feed in at full capacity. This implies that, under such traditional planning and no coordination of generation investments, distribution networks (lines and transformers) require significant upgrades once more than a modest amount of solar PV is installed. In some cases, grid costs can be of the same order of magnitude as the PV investment itself (Dickert et al. 2014).⁶²

If grid investments and small-scale generation investments are coordinated, and if grid planning is done in smart ways, costs can be greatly reduced (Consentec 2013, Imperial College 2014, Agora Energiewende 2015). For example, it might be sensible to connect solar PV plants at, say, 70% rather than 100% of peak capacity: saved grid costs are substantial while the amount of energy spilled is modest (below 3%, according to IAEW et al. 2014, p. 78).

Given the large size of distribution grids and the variation in grid topology and characteristics, it seems unrealistic that all system constraints can be dynamically priced, even in the long-term, without excessive transaction costs. For example, the costs of nodal pricing in distribution grids likely outweigh the benefits.

⁶² A recent German study (IAEW et al. 2014) projects that network fees will increase by 3% to 15% (depending on the region) if the target of 55% to 60% renewables in electricity generation by 2035 is to be met.

A benchmark market design should strike a balance, providing the most important scarcity signals to investors without excessive costs.

The following changes to market design should be considered.

- **Curtailement rules.** Command and control rules could be implemented to limit peak in-feed in clusters of decentralised generators in order to reduce stress on distribution grids. Such administrative rules can easily be implemented, but are not very efficient. For example, in some regions with little solar development, they could be connected at full capacity.
- **Zoning.** Zoning refers to the idea to address such regional differences by establish geographic zones where different rules apply. Grids that are close to its limits could be closed for additional investments while others could remain open. Ontario has introduced a system of “zoning” (green, yellow, red) that limits new installations in stressed grids.
- **Static price signals.** An even better signal would be site-specific price signals, for example in the form of (deep) grid connection or grid usage fees for generators that are connected to the distribution grid.
- **Dynamic price signals.** Finally, dynamic price signals could be introduced in the form of nodal pricing in distribution grids. Such pricing would signal to decentralised generators precisely when and where networks are loaded such that generation is adjusted cost-optimally. The informational and IT-requirements for this step are very substantial, as well as the complexity that consumers are facing, hence it is a long-term vision rather than a medium-term plan.

These four market design reforms could supplement each other, especially the first two. A combination of zoning and curtailment rules could be a simple but cost-effective way to limit distribution grid upgrade costs. Zoning should not be used, of course, to ban distribution-grid connected generation investments altogether, but to approximate a cost-optimal balance between generation and grid investments.

Benchmark market design elements	Potential issues	Examples in countries surveyed
Curtailement rules	Excessive cost for distribution grid upgrades in VRE hotspots	Curtailement rules for small-scale solar PV introduced in Germany (70% of nameplate capacity)
Zoning	Excessive cost for distribution grid upgrades in VRE hotspots	Zoning in Ontario
Static price signals	Location of VRE generation at locations where generation is cheapest, rather than at locations where the benefits (for the grid) are greatest	Project-specific connection fees in some countries; no locational distribution grid usage fee in any of the countries surveyed
Dynamic price signals	Production peaks at times when grid is already under stress	Time-varying locational prices in distribution grids are very challenging; currently not implemented nor discussed in any market surveyed

Table 26: Benchmark market design elements and gaps – distribution grid coordination

Source: FTI-CL Energy and NEON

8.6. MARKET ACCESS FOR DISTRIBUTED GENERATION

Traditionally, generation companies have had individual access to wholesale markets such as power exchanges or independent system operators in the form of trading departments. Market access has significant entry costs, ranging from 24/7 trading desks to back offices to access fees that power exchanges charge. Direct market access for thousands or millions of small-scale producers would lead to excessive transaction costs. Alternative models of market access are necessary for the distributed generators and prosumers, based on intermediaries that organise market access as a service to prosumers. Because they aggregate many small scale prosumers to reap economies of scale, such service providers are usually called “aggregators”. (Aggregators might also serve other clients, not only prosumers.)

Market access often also determines balancing responsibility and access to system service markets.

8.6.1. Benchmark market design

The setup of the market for aggregators and the rules for system service provision and balancing pose five potential challenges in the context of a prosumer-heavy power system with very high shares of variable renewables:

- Excessive transaction costs for small prosumers, if aggregators are inefficient and expensive;
- Excessive market access risk, i.e. the risk of not finding a suitable aggregator at all or the risk of an aggregator going bankrupt;
- Unfair distribution of balancing costs and lack of incentive to improve forecasts if balancing responsibility and charges are designed inefficiently;
- Conflict of interest if the system operator is also an aggregator, as it is then at the same time a market participant and the supposedly neutral operator of the power system;
- Discrimination against prosumers if system service markets are not technology-neutral and/or aggregator regulation is such that they cannot participate on system service markets such as balancing power.

A benchmark market design for market access avoids these problems.

8.6.2. Bridging the gap

Such models can help achieving the efficiency of the market design on a number of criteria, such as short-term operation efficiency and long-term investment efficiency, as well as help reaching efficient allocation of the risk. There are two approaches to market access for distributed generators and prosumers:

- **The single buyer model**, where a central entity sells all decentralised produced electricity to wholesale markets. This model reduces risk for prosumers and hence minimises the cost of financing. Single buyers were installed by many countries in the early years of feed-in-tariffs.
- **The aggregator model**, where different aggregators compete and prosumers can choose among them. An aggregator model fosters innovation via competition and might enable flexibility by providing efficient spot dispatch signals and market access to ancillary services.

A benchmark market design may achieve the best of both worlds: aggregators can provide market access for prosumers (to reap the benefits of competition); at the same time a regulated single buyer would offer “market access of last resort” (to reduce market access risk). If a single buyer is installed, it should not be the system operator in order to avoid conflict of interest.

Prosumers should be subject to balancing responsibility, while taking into account transaction costs. Balancing markets need to be designed such that no unnecessary costs are put on VRE and such that balancing costs are not higher than the marginal costs of balancing the power system. Benchmark system service markets are technology-neutral and allow participation of prosumers.

Market design element	Goals
Open and technology-neutral system service markets	End (implicit) discrimination against VRE in system service markets; fair incentives for VRE and other generators
Full balancing responsibility	Stop socialization of costs of forecast errors; provide incentive to improve forecasts
Aggregator of last resort	Avoid excessive market (access) risk for small-scale prosumers if absent
Aggregator competition	Induce competition, dynamic efficiency and innovation
Avoid system operator as aggregator	Avoid conflict of interest (one entity with two distinct and potentially conflicting roles)

Table 27: Benchmark market design elements and potential issues – market access and balancing

Source: FTI-CL Energy and NEON

Today, in many countries prosumers cannot choose between different aggregators that provide market access, and many system service markets are designed such that prosumers, or VRE more generally, are excluded from participation. The transition towards low-cost and barrier-free wholesale market access could follow these steps:

- **Reform of balancing markets.** Today, the design of procurement processes for balancing power in many countries is as such that wind and solar power, and prosumers, cannot participate fairly. Tender periods, minimum bid requirements and costly registration processes provide unnecessary barriers that should go (Hirth and Ziegenhagen 2015).
- **Full balancing responsibility.** Prosumers, as any other producers, should be fully responsible for deviations from production schedules. It is important that imbalance prices do not favour large portfolios, but are agnostic with respect to generator size. In countries where two-price rules prevail, for example in Sweden, this is not the case.
- **Neutral actor.** In order to avoid strategic behaviour, market access should be provided by a neutral actor, not by the system operator. The actor could be a dedicated, regulated service company. In some European countries, including Germany, the system operators provide market access.
- **Open aggregator market.** The aggregator market should be liberalised, such that prosumers can choose the aggregator they like. This introduces competition and fosters innovation. A state-organised “aggregator of last resort” should prevail to limit risks for prosumers.
- **Tender aggregator of last resort.** This aggregator should be chosen every couple of years in fair and public auctions based on least costs.
- **Free aggregator competition.** Once a robust aggregator market is established, the “aggregator of last resort” should terminate. The aggregator market continues to be monitored for market power, just as any other market.

Benchmark market design elements	Potential issues	Gaps / issues in countries surveyed
Open and technology-neutral balancing markets	(Implicit) discrimination against VRE in system service markets	Implicit barriers identified in many markets, e.g. long dispatch intervals in Germany
Full balancing responsibility	Socialization of costs of forecast errors	Balancing responsibility implemented or reform under the way in most jurisdiction
Aggregator of last resort	Excessive market (access) risk for small-scale prosumers	Existing in most markets
Aggregator competition	Monopoly with associated lack of efficiency and innovation incentives	Reform under the way or implemented in most markets (e.g. “direct marketing” in Germany)
Avoid system operator as aggregator	Conflict of interest	Still the case in Germany

Table 28: Benchmark market design elements and gaps – market access and balancing

Source: FTI-CL Energy and NEON

9. POLICY RECOMMENDATIONS

9.1. CROSS CUTTING CHALLENGES ASSOCIATED WITH HIGH SHARES OF VRE AND POLICY RECOMMENDATIONS

In Section 4, we outlined the challenges that high shares of VRE present to power systems and to power market design:

- **Capital intensity and low variable cost.** A system with high shares of VRE would have highly variable marginal cost and relatively high capital cost. The variable cost and the resulting energy price would frequently be low, when set by the marginal cost of VRE, and occasionally high, when determined by the supporting technologies. The shift towards a system with a more volatile marginal cost creates significant challenges for investment in generating capacity, both VRE and flexible, because of the increased market risk exposure on risk adverse investors. This would require the implementation of additional risk hedging instruments.
- **Limited predictability and variability.** A system with a high share of VRE would increase the variability of the demand for flexible resources and conventional plants. Flexible resources would also need to be remunerated for the flexibility provided to back-up VRE rather than for energy. More volatile prices may also create an additional need for market power monitoring and mitigation policies. Reduced predictability of VRE output would shift the operational timeframes from day-ahead and closer to real-time, requiring changes in the spot market design to accommodate faster trading and/or dispatch decisions made on a larger scale and shorter time-frame. A system with a high share of VRE featuring larger deviations from predicted schedules would require a different approach to system operation and hence different amounts and types of ancillary services.
- **Decentralised and scattered generation.** In a high-VRE power system, a significant part of generation is likely to be decentralised and far from load centres. This implies challenges for market design to coordinate between transmission grid, distribution grid, and generation expansion, and to address issues around the production from distributed customers (prosumers).

VRE property	Power system challenges	Market design challenges
Capital intensity	Changing cost structure Optimal generation mix shifts	Fixed cost recovery, cost of capital Credible investment incentives
Limited predictability and variability	Short-term dispatch coordination Time horizon of power system operations shortens Assurance of system stability	Price volatility and uncertainty Spot market design Design of ancillary services
Decentralised and scattered generation	Transmission and distribution grid planning and operation	Geographic coordination between generation and grids Prosumers: retail pricing and metering rules

Table 29 : How challenges to power systems turn into challenges to market design

Source: FTI-CL Energy, NEON

In the previous sections, we outlined four main prototypes of market system organisation: energy-only market, hybrid market, vertically integrated system and prosumer market. We then identified the ‘ideal’

market design benchmark for each of these prototypes, indicated the gaps between the current market designs and the benchmarks, and suggested some policy options to reach these benchmarks.

Whilst there is no silver bullet market design, this report provided both high level policy recommendations that are valid in general, as well as more specific policy recommendations for some key power market prototypes in the wholesale and in the retail markets.

Regardless of the market prototype, a policy maker may need to address three main areas to ensure a smooth transition to a system with high share of VRE:

- Short-term system operations;
- System development and investment; and
- Governance and regulatory framework.

Recommendations for short term system operation

Large shares of VRE imply that the **power system will need to be balanced closer to real time**, which requires a **market design that appropriately reflects short term system operation costs**. Therefore, the market design of the short-term markets and ancillary services should evolve in the following direction:

- Remove barriers to scarcity pricing to allow power prices to convey the high value of electricity at times of scarcity.
- Ensure that the market design creates a level playing field and fosters the development of flexibility in its various forms (storage, DSM, new cross border lines etc.).
- Introduce locational signals to coordinate in real time many decentralised players and transmission and distribution networks, either through the implementation of nodal/zonal prices or through local markets for ancillary services.
- Develop new risk hedging and risk transfer mechanisms specifically tailored to the new types of risks, e.g. hedging products for intraday / balancing price volatility.
- Revisit the optimal mix of decentralised (price based) and centralised (planned) steering mechanisms.

Recommendations for optimal system development and investment

A power system with large shares of VRE creates a number of **challenges for investors, in order to manage the capital intensity, fixed cost recovery issues, and risk exposure**. To meet these challenges, the market design evolution should include:

- Policies supporting the development of efficient risk transfer and risk hedging mechanisms will be needed to ensure the financeability and bankability of capital intensive technologies and to reduce the cost of capital.
- The market design should introduce long-term coordination mechanisms for the decision on siting and timing of investment across centralised / decentralised generation capacity and network expansion.
- A regulatory framework of the network development should evolve to include necessary elements of incentive regulation to drive efficient and timely development of the grid infrastructure.

Recommendations on governance and regulatory framework

The rise in the share of VRE technologies will require **changes in the governance and regulatory framework** in a consistent way with the market design:

- Policies supporting technological innovation and smart, unconventional solutions are needed. In particular, the regulatory framework for the transmission, distribution and market operators needs to incorporate incentives for innovation and investments in smart grids. Policy makers might consider the creation of a new independent regulatory agency with proactive mandate to drive the transition.
- An efficient allocation of responsibilities between the different geographic levels of governance is warranted. This may require revisiting the role of the TSO / ISO, as well as the interface and responsibilities of the TSO and DSOs. In addition, an efficient governance of energy at a local level and interface with the national and regional levels needs to be put in place.

In addition to these general recommendations, the next subsections focus in greater details on the policy recommendations for each of the prototypes and across prototypes. We also indicate the drivers that would determine the transition paths and the policy recommendations for implementation of these paths.

- We first present our policy recommendations for the wholesale market design based on the analysis of the energy-only, hybrid and vertically integrated power system prototypes.
- We then present our policy recommendations for the market design related to the interaction between the retail and wholesale markets, based on the discussion of the prosumer market prototype.

9.2. WHOLESALE MARKET DESIGN POLICY RECOMMENDATIONS

In this subsection we present the recommendations for the wholesale market design. We start by presenting the policy recommendations for the energy-only and vertically integrated market prototypes.

In practice, most electricity markets today are hybrid markets with some form of regulatory intervention and a role for the state in planning and/or capacity procurement. In the case in which the development of flexibility would be insufficient, high shares of VRE may require the introduction of further elements of the hybrid market prototype, as discussed in section 3. We therefore first examine the possible drivers of a transition towards a hybrid system and then propose specific hybrid elements that may be necessary in different situations.

9.2.1. Energy-only market policy recommendations

We summarise below the policy recommendations for three main areas of market design in the energy-only market that are critical and may need evolution at high VRE shares that a policy-maker should address. They are relevant for all markets that share the key characteristic of the energy-only prototype, namely relying on the spot and ancillary services markets for short-term dispatch and long-term investment decisions.

Design of spot and ancillary services markets

The variability and uncertainty of wind and solar power is likely to change the time structure of wholesale prices. Significant changes in the market design will be required to ensure these prices remain an accurate indicator of value of energy in the short run and a reliable signal for investment in the long run.

- **Harmonise market designs across time frames and across markets.** Foster more harmonisation in market design to facilitate cross-border trading and arbitrage across time, and to limit distortions. Examples include: intraday, forward cross-border capacity allocation, dispatch regimes (including suppressing priority dispatch for RES). Such market design harmonisation is already envisaged under the European Target Model.

- **Increase price caps and remove barriers to scarcity pricing.** Price caps used in most markets are too low to signal scarcity at the level that represents the value of lost load for customers (for example, the current price cap is 3,000€/MWh in many European markets). In addition, a number of operational constraints can prevent power prices to fully reflect the value of scarcity in case of shortages. An increase in price caps combined with a removal of the various barriers to scarcity pricing is needed. Such an increase can be introduced gradually to allow market participants and regulators to adapt to the new realities and be accompanied by the introduction of hedging products.
- **Implement clear and non-distorting market abuse rules.** In addition to the price caps, operational procedures and regulatory constraints for market power monitoring and prosecution of market power abuse may prevent the price from increasing sufficiently high in times of scarcity. Such procedures should be determined clearly in a way that distinguishes market power and market abuse from scarcity pricing. In Europe, these procedures can be developed under the current REMIT and competition regulations.
- **Improve balancing markets.** Introduce marginal pricing and single price imbalance settlement in the balancing markets in order to provide a short term price signal that represents the cost of balancing the system. This approach would remove the barriers to arbitrage between real-time balancing markets and markets for intraday and day-ahead trading. This would allow scarcity to be better reflected along the forward curve. However the transition needs to be managed carefully as this could also impact the split of balancing responsibilities between market participants and the TSO.
- **Improve operating reserve markets.** Implement market-based hourly procurement of operating reserves. Procurement of reserves with the same frequency as energy or even their co-optimisation will improve the valuation of flexibility and the consistency of the scarcity price signal between balancing and operating reserve markets.
- **Allow demand side response (DSR) participation in all market segments.** There are significant benefits in ensuring a level playing field between generation and DSR in all markets. Best practices in terms of product design need to be shared to avoid discrimination against DSR.
- **Promote dynamic retail pricing approaches.** Remove regulated tariffs for retail prices and promote more cost-reflective and time-varying prices for end consumers, in order to extract benefits from smart meter deployment.

Locational price signals

In a high-VRE power system, a significant part of generation is likely to be decentralised and far from load centres. This implies a number of challenges for market design to coordinate between (transmission and distribution) grid expansion and generation expansion.

In jurisdictions that do not have geographically differentiated price signals, the introduction of zonal splitting could be an evolutionary short-term measure aimed at creating such price signals. This is the case in European markets sharing the characteristics of the energy-only prototype, many of which currently feature markets with a single price maintained within national borders. The ongoing bidding zone review may result in zonal configurations that are more granular than a national level.

A more radical measure could be the introduction of a nodal price system. However, the recent experience of Texas and California suggests that a transition from a zonal to a nodal system can be quite challenging, time consuming and can face significant stakeholder opposition. Such transitions in the European markets may for instance be difficult, as it may also require revising the roles of TSOs and Power Exchanges.

The complexity of implementation of nodal prices may lead policy makers to investigate other options, such as sending price signals through transmission usage or connection charges. In addition, innovative

products introduced by power exchange operators may introduce some form of differentiated price signal in different zones for system balancing.

Development of hedging products

As electricity markets mature around the world, a number of hedging products and instruments have emerged. However, electricity markets are still believed to provide incomplete hedging possibilities to market participants.

One key issue is the lack of trading products and liquidity in the medium to long term (there are very few trades beyond 3 years ahead of real time in most markets). Measures to improve opportunities for voluntary forward hedging could involve introducing new standard products on trading platforms. Such new products could take the form of the cap products used in the NEM market in Australia which allow retailers to hedge against potential high prices. Alternatively, policy makers and regulators may choose to implement obligations for long term contracting – at least in a transitory phase – in order to stimulate the development of long term hedging products.

Besides, the growth of intermittent renewables increases the need of short term hedging products. There is a need for new hedging products to emerge, such as the “cap future” product traded on the German power market to allow market participants to hedge against intraday price variations.

The market demand for such products would be driven by the intensity of price spikes in the intraday electricity market. As long as the price spikes rarely occur or are small, due to explicit or implicit price caps, market participants may not see a need for such products.⁶³ So, these measures should be considered in combination with measures intended to make the spot prices more reflective of the scarcity system costs described above.

9.2.2. Vertically integrated system recommendations

Policy recommendations for the vertically integrated power system prototype are relevant for markets that share the characteristics of the vertically integrated prototype: relying on centralised decision-making both for the short-term dispatch and long-term investment decisions. In a **vertically integrated utility**, a policy-maker should address three different areas of market design are critical at high VRE shares.

Adopt an efficient regulatory framework

- Implement incentive regulation to foster deployment of low carbon technologies and support the development of the enabling infrastructure, as well as sources of flexibility such as storage, DSM, etc.
- The regulation framework for efficient system development needs to extend beyond the regulation of the incumbent utility and delegate the planning role to a neutral third party (e.g. an ISO). Cross border cooperation for system planning and operation should be encouraged.

Apply transparent and non-discriminatory rules for third-party access

This is particularly relevant in the case of RES investment, which is often provided by IPPs and not the incumbent utility.

⁶³ The cap products introduced in Germany are not traded in large volumes as of today, but this could be due to low prices and the low frequency of price spikes due to overcapacity.

- Apply transparent and non-discriminatory rules for third-party access. These may include RES-specific measures, such as facilitating regulatory approval and streamlining network connection procedures. Planning and licensing procedures could be adapted to meet the specific requirements of renewables projects.
- The third-party access arrangements may go beyond the requirements for the incumbent to provide third-party access and delegate connection and dispatch roles to a neutral third party, such as an independent regulatory agency or an ISO.

Facilitate cross-border trading arrangements

High shares of RES may require increased volumes of power trading with neighbouring areas to leverage flexibility existing cross-border to facilitate balancing of RES.

- Implement regulation and legal frameworks allowing and encouraging bilateral cooperation on electricity trading.
- Develop regional cooperation to ensure secure operation of the electricity system. This may include regional cross-border sharing of operating reserves, and regional standards for system security. This may also require implementing a regional coordination agency, with a mandate to optimise system operation on a regional basis, such as the WECC in the US.

9.2.3. Hybrid market policy recommendations

Drivers determining transition to hybrid approaches

The challenges presented by high shares of VRE for market design may require introduction of hybrid system elements, combining the centralised and decentralised approaches for either the short-term system operation and / or the long-term system development. In our view, the choice of a hybrid system will be determined by the two main drives:

- the policy-maker's tendency for intervention and
- the flexibility of the system provided by storage, DSR and interconnection.

We present below more details on these drivers.

Different countries feature a range of attitudes from policy makers between decentralisation (market-based) and centralisation (state-based) of decisions in matters of energy policy. The degree of a policy-maker's intervention and the resulting tendency for centralised solutions may be determined by the following properties:

- **Policy-maker's attitude to risk.** This refers to policy maker's acceptance of the uncertainty in market outcomes. A high share of VRE increases the uncertainty of market outcomes such as prices and investment patterns. Facing such uncertainty, some risk-averse policy makers may want to take responsibility and centralise the decision-making processes and market design in order to reduce such uncertainty.
- **Policy-maker's information asymmetry.** This refers to the degree of information regarding market participants available to the policy maker and therefore a policy-maker's ability to manage complex processes efficiently in a centralised manner. There is often an information asymmetry between market participants and policy makers, for instance on the costs of production which may prevent a centralised dispatch process to be efficient. High shares of VRE make certain centralised processes increasingly complex and the distributed nature of VRE is likely to increase the asymmetry of information.

This driver refers to the development of the generation mix along the decarbonisation path leading to high shares of VRE. As discussed in section 4, there is a strong link between the resource mix (in particular the flexibility of the system provided by storage, DSR and interconnection) and the resulting temporal structure of the system marginal cost and power prices.

Depending on the development of the future generation mix (particularly whether biomass and/or CCS feature significantly), as well as various forms of flexibility such as DSR, storage, or interconnection, one can expect to see a very different cost structure and thus power price dynamics :

- **In case of low system flexibility**, price dynamics would likely be characterised by very low or zero system marginal cost for a large number of hours as well as rare but significant spikes of system marginal cost during scarcity periods. In such a world, a different market design model would likely be needed both for the short term dispatch and for the long term investment incentives, and the introduction of some additional coordination and risk sharing mechanisms would be needed.
- **In the opposite case**, in a system with a significant share of low carbon technologies with significant variable cost and/or sources of system flexibility such as storage, DSM, or interconnection with neighbouring power systems allowing access to their flexible resources, power prices would unlikely become excessively volatile. In such a power system with significant flexibility, pricing and market design may not be fundamentally different from today.

A mix with higher flexibility therefore reduces the urgency and need for radical changes to market design to deal with the challenges presented by VRE and allows a smooth transition of the market design. Policies supporting the development of flexibility are therefore necessary to facilitate the transition to a power system with high shares of VRE.

Conversely, in power systems with low embedded flexibility, or in case the potential for the development of flexibility in a timely way would be low, some more radical changes would likely be needed involving a transition to hybrid power market approaches. The next section concentrates on this transition toward hybrid approaches.

Engineering the transition to hybrid approaches

Below we discuss the choice of a hybrid intervention determined by the two drivers presented above.

In countries in which policy-makers that have a limited tendency to intervene in matters of energy policy, for example, where policy-makers do not determine the generation mix by supporting specific technologies, one can consider the following possibilities:

- **In the case of a highly flexible system**, the temporal structure of power prices will not be dramatically eroded by the high volumes of VRE. As a result, **energy-only markets** can provide efficient incentives, both for the short-run operation and dispatch and for the long-run investment decisions. The energy-only market would need to be improved along the lines presented above, mainly to allow efficient scarcity pricing and locational prices.
- **In the case of a less flexible system**, worries about security of supply and lack of investment in flexible capacity may need to be dealt with through a mechanism specifically targeted at maintaining the degree of security at the level prescribed by policy makers. This could involve for instance reforms to implement a **capacity mechanism** that aims to deliver a target level of security of supply, and / or gives providers of flexible capacity additional remuneration. A capacity market can be designed so that many decisions remain decentralised and market based, but intervention is needed to define the product and security of supply obligations for retail suppliers.

Policy-makers with a greater tendency to intervene in the market, for instance to support the deployment of some specific technologies or to ensure that sufficient capacity is built, could choose to implement additional coordination and/or risk transfer mechanisms. In practice, this could lead to a two-step hybrid market, with a first step consisting in an ‘investment market’ with tenders for long-term capacity contracts and a second step consisting in ‘competition in the market’ for short term spot and balancing markets operation:

- **In the case of a highly flexible system**, the introduction of a two-step market design with a first **technology-neutral investment tendering phase** could be considered, since there is no specific need to foster the development of flexible technologies.
- **In the case of an inflexible system**, a technology-specific investment market involving **tenders by category of RES and complimentary flexible technologies** could be the way forward, in order to ensure the technology mix develops towards a flexible system.

These policy decisions on transition towards a hybrid market are summarised in Figure 34 below.

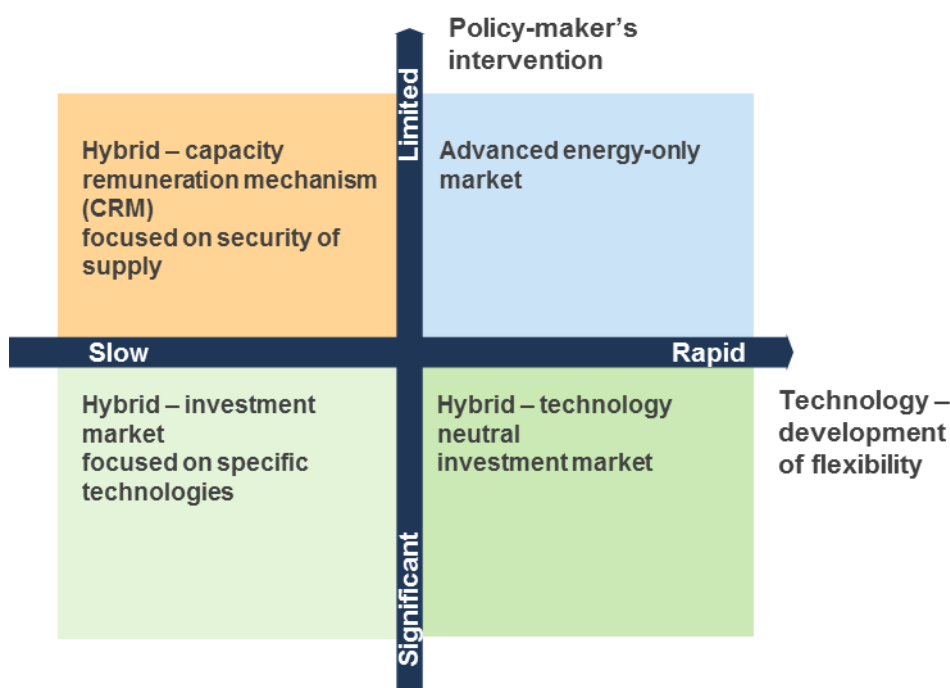

Figure 34: Wholesale market transitions

Source: FTI-CL Energy and NEON

Thus, depending on the two main drivers three general types of hybrid systems can be identified in addition to the energy only market improved through the policy recommendations:

- Support to flexible capacity through a capacity or flexibility mechanism that would aim to deliver a target level of security of supply, and to give providers of flexible capacity additional remuneration;
- A two-step hybrid market (an investment market in the first step and a short term spot markets operation in the second step) with a technology-neutral investment tendering first phase; and
- A two-step hybrid market (an investment market in the first step and a short term spot markets operation in the second step) with a technology-specific investment market involving tenders by category of RES and complimentary flexible technologies.

Hybrid market policy recommendations

Once the decision on a type of a hybrid market is made, a policy maker should address the following three areas of market design that are critical with high VRE shares.

Ensure efficient integrated resource planning

The integrated resource planning process should be able to achieve an efficient allocation between VRE and flexible resources using as much information on the demand and technology forecast as is available. Under the benchmark design developed in Section 7, the central planner would run an efficient, transparent and non-discriminatory procurement process for the planned capacity.

An efficient resource planning process may be achieved by setting a clear mandate for the independent planning agency and ensuring its incentives are well aligned through correct governance. For example, an efficient planning process is more likely to be achieved by an independent planning agency than by the government or the incumbent utility. This is because the decisions of the state authorities may be biased by other interests.

Carefully design the interface between centralised and decentralised processes

Bringing the interface between the centralised and decentralised processes closer to the benchmark market design can be achieved through:

- Ensuring the long term contracts serving as mandatory risk sharing instruments do not associate payments with short-term operation, such as production of energy or ancillary services. Any such association would inevitably distort incentives for efficient short-run operation;
- In case of capacity contracts, ensuring product definition and procurement process measures of available capacity eligible for payment is not directly or indirectly related to the output of plants;
- Designing the products in a way that allows and encourages participation of renewables; and
- Accounting for specificities of RES cost structure to design mandatory hedging contracts that allow an efficient risk allocation and support the financing of capital intensive technologies.

Award mandatory risk hedging contracts through transparent auctions

Bringing the organisation of mandatory risk-hedging instruments closer to the benchmark market design would require:

- Awarding the risk-hedging contracts through a transparent auction-based procurement process;
- Designing auctions' procurement processes so that they encourage participation of renewables, storage and demand response providers;
- Where possible, favouring a decentralised procurement to allow contracts to be tailored to meet the specific needs of suppliers and capacity providers.

9.3. RECOMMENDATIONS FOR RETAIL MARKET DESIGN

Development of high shares of VRE is associated with development of the prosumer market, that is, customers that are active in production on their consumption site. Such auto-production is often done from variable renewable sources, such as solar PV.

A policy-maker should first understand the drivers of the development of the prosumer market in a market with high shares of VRE to be able to choose an appropriate policy. Below we first describe the

drivers determining the transition to a prosumer market and then provide the policy recommendations for retail market design.

9.3.1. Drivers determining the transition

Traditionally, electricity consumption was characterised by two properties: most consumers showed little interest in the way power was generated; and electricity was sold as a commodity where customers pay per kWh of consumed energy. Both characteristics might change in the future with radical implications on market design, especially in the prosumer markets.

Prosumer attitude

A crucial aspect of the long-term role of consumers and prosumers is their degree of engagement. Many factors might increase the intrinsic (i.e., non-monetary) interest of consumers in electricity generation, such as: status and life-style; the gamification of energy supply; an “early adopter” attitude towards energy technology; or, in the case of service and industrial prosumers, the positive image associated with auto-generation.

Compared to consumption goods like mobile phones, apparel, or cars, electricity comprises a very small share of household expenditure. In a world where energy consumption and production becomes as emotionally loaded as these goods, monetary incentives are likely to play a smaller role and the role of prices as coordination and risk sharing mechanism may become less relevant.

Commodity vs. service

Another crucial aspect for the role of prosumers is a potential change in the type of good that is bought by consumers. As mentioned in Section 4, transition to high shares of VRE associated with low marginal cost of electricity may also be accompanied by accelerated transition of the retail pricing from commodity pricing towards service-oriented goods. These developments could have a dramatic impact on the way the retail electricity market is designed.

- Energy-related services, rather than electricity as a commodity, might be the good that is traded.
- Auto-generation and self-consumption might be driven by emotional engagement and gamified software application, rather than price savings.
- Investment in auto-generation equipment might be able to access very low-cost finance, if it is seen by households as consumption or life-style spending, rather than an investment decision.
- The role of intermediaries such as aggregators might become more important for retail business models compared to today.

This development would imply a significant change in the way prosumers would interact with the electricity market. However, the analysis and recommendations of Section 8 would still remain valid and relevant. If the prosumer contracts an aggregator/intermediary such that he is not exposed to price signals himself, it is the aggregator that should be subject to the retail price signals as they are discussed in Section 8.

Depending on how these two drivers play out in the long-term future, the role and the type of prosumer development could be very different. If electricity continues to be traded as a commodity, the following development is possible:

- **Engaged prosumers** (upper left quadrant of Figure 35), who are motivated by non-monetary incentives to engage in electricity generation, would allow a **dynamic prosumer market** development under the

benchmark market design outlined above. In this case, wholesale and retail prices are consistent, but status, life-style, gamification, and access to low-cost private financial resources provide sufficient incentives to cover any remaining cost gap between small-scale and large-scale VRE investments. In this scenario, companies (in contrast to households) are unlikely to auto-generate in large volumes.

- **Without engaged consumers** (lower left quadrant of Figure 35), explicit monetary incentives are required to drive prosumer development. One possibility to do so is to **disassociate the retail prices from the wholesale markets**, much like it is currently done. However, as was shown above, this creates a number of problems and is not efficient. Policy recommendations for the ideal market design can be implemented but they will likely slow down prosumer market development.

If electricity is traded as part of an energy and smart home (or other) services bundle, the outlook might look very different. Retail pricing of electricity as a service, like in the telecommunications industry today, would change the incentives of customers to self-generate and would determine the policies on which the focus should be made. Flat rates and paid add-on services may materially decrease the monetary incentives for customers to auto-produce and would make the prosumer market unviable.

- **With engaged consumers** (upper right quadrant of Figure 35), **self-consumption would become part of the energy service bundle** sold to the household. It would become a feature of the product that retailers sell to end-consumers. Retail suppliers would monetise the status, life-style, and enjoyment derived from generating electricity at home. The degree to which companies (in contrast to households) would engage in auto-generation depends on the monetary incentives they are faced with.
- **Without engaged consumers and in the absence of commodity retail electricity** pricing (lower right quadrant of Figure 35), it could be **difficult to induce direct participation of prosumers**. The market design under which retail service companies trade electricity with the wholesale market would become important. In most cases monetary incentives for small-scale local electricity generation would be insufficient to compete with large-scale VRE investment. If such a benchmark design is not implemented, the intermediaries would invest and capture the benefits, with the problems and inefficiencies outlined above in section 8.

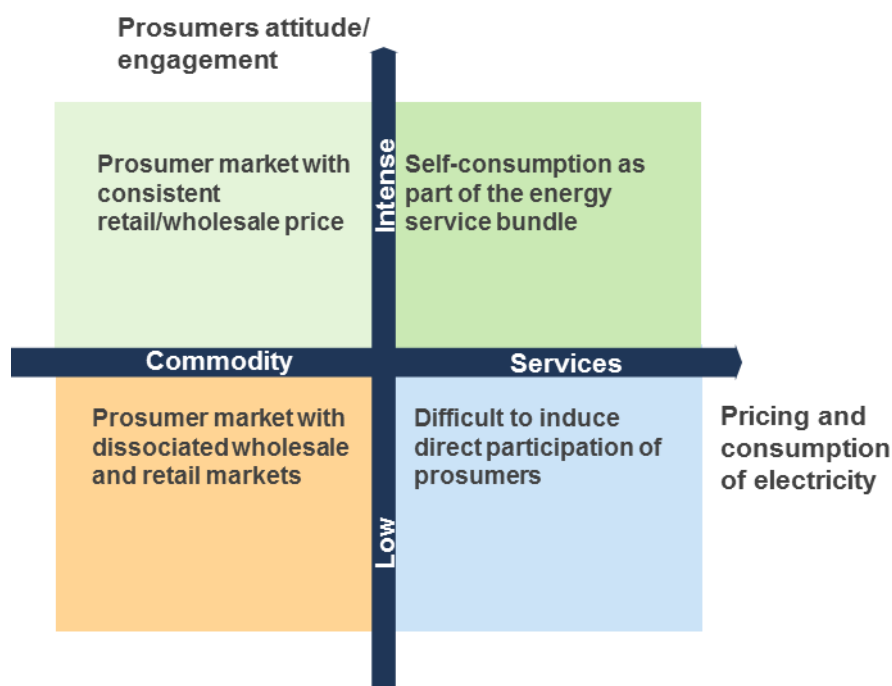

Figure 35: Retail/wholesale market organisation

Source: FTI-Cl Energy and NEON

Thus, in our view, depending on the two drivers, a prosumer market may develop in three ways:

- Spontaneous prosumer market development with consistent wholesale and retail prices;
- Prosumer development requiring monetary incentives through dissociation between wholesale and retail prices; and
- Prosumer development induced through energy service bundles sold to customers by aggregators.

9.3.2. Prosumer market recommendations

Once the policy maker is set on the development path of the prosumer market as outlined above, it will need to focus on four areas of market design are critical for high wind and solar penetration, as identified in section 8:

- **Adapt retail pricing and metering rules to account for their new role as investment incentive.** Consumers make consumption and investment decisions based on price signals they receive through retail electricity tariffs, rather than wholesale electricity prices. The effective price received for self-consumed electricity depends on the level and structure of retail prices and on the way consumption is measured (e.g., net metering). The fact that the retail price provides the investment signal for prosumers can be problematic for three reasons: investment incentives might be distorted vis-à-vis non-prosumer investments; prices might fail to signal system needs; and the income of governments and system operators might decline. Possible responses to these challenges include the alleviation of retail prices from charges and taxes, more cost-reflective grid tariff structures, and/or the taxation of self-consumed electricity.
- **Redesign regulation of distribution network operators (DSOs) with focus on (smart) investments.** Small-scale prosumers are typically connected at low voltage levels to the distribution grid. Auto-generation as well as other demand-side participation in electricity markets often requires upgrading distribution networks. Smart grid technologies can often help to contain costs. Regulation should focus more on investment incentives and innovation.
- **Provide locational signals to investors within distribution grids.** An important means to limit distribution grid costs is to coordinate generation and grid investments. This requires some signal to prosumer investors where and where not to invest; such signals have traditionally not existed in all jurisdictions. Developing a feasible mechanism to reflect grid costs and provide efficient signals to grid users and investors is of critical importance.
- **Provide market access and apply balancing responsibility.** Unlike large-scale generators, prosumers access wholesale markets through intermediaries, or aggregators. A good market design assures low-cost market access, competition among aggregators, and balancing responsibilities to prosumers.

10. REFERENCES

- Abbad, J.R., 2010. Electricity market participation of wind farms: the success story of the Spanish pragmatism. *Energy Policy* 38, 3174-3179.
- ACER, 2014. Report on the influence of existing bidding zones on electricity markets
- AEMC, 2013. NEM Financial Market Resilience
- Barquin, J., Rouco, L., Rivero, E., 2011. Current designs and expected evolutions of Dayahead, Intra-day and balancing market/mechanisms in Europe, in: OPTIMATE (Ed.).
- Batlle, C., Pérez-Arriaga, I.J., Zambrano-Barragán, P., 2012. Regulatory design for RES-E support mechanisms: Learning curves, market structure, and burden-sharing. *Energy Policy* 41, 212-220.
- BDEW (2015): Entwicklung des Stromverbrauchs in Deutschland, Bundesverband der Energie- und Wasserwirtschaft, Berlin.
- Borggreffe, Neuhoff, K., 2011. Balancing and intra-day market design: options for wind integration, in: Initiative, C.P. (Ed.), European Smart Power Market Project.
- Braziel, R, 1998. Trading Hubs: Where Power Is Traded And Why.
- Burtaw, Dallas & Sahra Jo Szamelan (2011): "US emissions trading markets for SO2 and NOx", in: Bernd Hansjürgens, Ralf Antes & Marianne Strunz (eds.): Permit Trading in Different Applications, Routledge.
- Castalia Strategic Advisors, 2013. International Experience with Single Buyer Models for Electricity
- Chao, H.-p., 2011. Efficient pricing and investment in electricity markets with intermittent resources. *Energy Policy* 39, 3945-3953.
- Consentec (2013): "Kostenoptimaler Ausbau der Erneuerbaren Energien in Deutschland", report for Agora Energiewende.
- Cossent, R., Gómez, T., Olmos, L., 2011. Large-scale integration of renewable and distributed generation of electricity in Spain: Current situation and future needs. *Energy Policy* 39, 8078-8087.
- Cossent, Rafael (2013): Economic Regulation of Distribution System Operators and its Adaptation to the Penetration of Distributed Energy Resources and Smart Grid Technologies, Ph.D. thesis, Universidad Pontificia Comillas, Madrid.
- Cramton, P., Ockenfels, A., 2011. Economics and design of capacity markets for the power sector. mimeo.
- CRE, 2008. Results of investigations into record high electricity price peaks on Powernext Day-ahead Auction in October and November 2007
- De Vos, K., De Rijcke, S., Driesen, J., Kyriazis, A., 2011. Value of Market Mechanisms Enabling Improved Wind Power Predictions: A Case Study of the Estinnes Wind Power Plant.
- De Vries, L.J., 2007. Generation adequacy: helping the market do its job. *Utilities Policy* 15:1, 20-35
- Department of Energy & Climate Change, 2010. Energy Market Assessment
- Dickert, Jörg, Peter Schegner, Hanjo During & Jan Kober (2014): „Sensitivitäten von Netzausbaumaßnahmen durch den Anschluss von PV-Anlagen an das Niederspannungsnetz“, VDE Kongress.
- EC 2011. Regulation (EU) No 1227/2011 of the European Parliament and of the Council of 25 October 2011
- Ecofys & Fraunhofer ISI (2015): Stromkosten der energieintensiven Industrie Ein internationaler Vergleich, report for Bundesministeriums für Wirtschaft und Energie, Berlin.
- El Gammal et al., 2015, PV development as prosumers: the role and challenges associated to producing and self-consuming PV electricity
- Energy Strategies, 2009. Overview of Issues at the Western Electricity Coordinating Council (WECC)
- Eurelectric, 2011. RES integration and market design: are capacity remuneration mechanisms needed to ensure generation adequacy?
- Euroelectric, 2015. Prosumers – an integral part of the power system and the market

- EWEA, 2015. MARKET DESIGN A position paper from the European Wind Energy Industry
- Fabra, N. and J. Toro, 2005. “Price Wars and Collusion in the Spanish Electricity Market,” *International Journal of Industrial Organization* 23:3-4, pp. 155-181.
- Financial Mail, 2014. Eskom's power crisis is far from over
- Finon D. and V. Pignon, 2008. Electricity and Long-Term Capacity Adequacy, *The Quest for Regulatory Mechanism Compatible with Electricity Market*, *Utilities Policy*, 16:3
- FTI-CL Energy, 2015. *Toward the Target Model 2.0: Policy Recommendations for a Sustainable EU Power Market Framework*
- Gawel, E., Purkus, A., 2013. Promoting the market and system integration of renewable energies through premium schemes: A case study of the German market premium. *UFZ Discussion Papers*.
- Glachant, J.M., Henriot, A., 2013. Melting-pots and salad bowls : the current debate on electricity market design for RES Integration. *MIT CEEPR*.
- Gottstein, M., Schwartz, L., 2010. The role of forward capacity markets in increasing demand-side and other low-carbon resources: experience and prospects. *Montpelier, Vt.: Regulatory Assistance Project*.
- Green, R., 2008. Electricity Wholesale Markets: Designs Now and in a Low-carbon Future. *Energ J*, 95-124.
- GWEC, 2011. *Global Wind Report*
- Henriot, A., 2012. Market design with wind: managing low-predictability in intraday markets.
- Henriot, A., Vazquez, M., Hallack, M., Glachant, J.M., 2012. *LDP Academic Roundtable Redesigning Gas and Electricity Markets to Work Together*.
- Hiroux, C., Saguan, M., 2010. Large-scale wind power in European electricity markets: Time for revisiting support schemes and market designs? *Energ Policy* 38, 3135-3145.
- Hirth, L. and Ziegenhagen, I., 2015. *Balancing Power and variable renewables: three links*, *Renewable and sustainable energy reviews*, v5
- Hogan, W.W, 2014, “Electricity scarcity pricing and resource adequacy,” *Harvard Electricity Policy Group*
- Hogan, W.W., 2005. On an “Energy only” electricity market design for resource adequacy.
- Hogan, W.W., 2010. *Electricity Wholesale Market Design in a Low-Carbon Future. Harnessing Renewable Energy in Electric Power Systems: Theory, Practice, Policy*, 113.
- Holttinen, H., Meibom, P., Orths, A., van Hulle, F., Lange, B., O'Malley, M., Pierik, J., Ummels, B., Tande, J.O., Estanqueiro, A., 2009. *Design and operation of power systems with large amounts of wind power: Final report, IEA WIND Task 25, Phase one 2006-2008. VTT Technical Research Centre of Finland Helsinki*.
- IAEW, E-Bridge & Offis (2014): *Moderne Verteilnetze für Deutschland (Verteilnetzstudie)*.
- IEA, 2008. “Empowering Variable Renewables Options for Flexible Electricity Systems”
- IEA, 2011. “Harnessing Variable Renewables: a Guide to the Balancing Challenge”
- IEA, 2014. “The Power of Transformation – Wind, Sun and The Economics of Flexible Power Systems”
- IEA, 2014. *Energy technology perspectives*
- IEA-RETD (2014): *Residential Prosumers – Drivers and Policy Options (Re-Prosumers)*, *International Energy Agency Renewable Energy Technology Department, Paris*.
- IEA-RETD (2015): *Roof-top solar PV prosumers in remote areas and islands*, *International Energy Agency Renewable Energy Technology Department, Paris*.
- IEA-RETD (2016): *Tapping the potential of Commercial Prosumers – Drivers and policy options*, *International Energy Agency Renewable Energy Technology Department, Paris*.
- Imperial College, NERA Economic Consulting & DNV GL (2014): *Integration of Renewable Energy in Europe*.
- Jenkins, J.D., 2014. Economic regulation of electricity distribution utilities under high penetration of distributed energy resources : applying an incentive compatible menu of contracts, reference network model and uncertainty mechanisms
- KEMA, 2011. *Distributed generation in Europe - Physical infrastructure and Distributed Generation Connection*.

- Keppler, J.H., Cometto, M., 2013. Short-term and Long-Term System Effects of Intermittent Renewables on Nuclear Energy and the Electricity Mix.
- Mastropietro, P., Battle, C., Barrozo, L.A., and Rodilla, P., 2014. Electricity auctions in South America – Towards convergence of system adequacy and RES-E support, Renewable and sustainable energy reviews, v40
- Montmasson-Clair, G., Moilwa, K., Ryan, G., 2014. Regulatory Entities Capacity Building Project Review of Regulators Orientation and Performance: Review of Regulation in Renewable Energy Trade and Industrial Policy Strategies (TIPS)
- Neuhoff, K., Ruester, S. and Schwenen, S., 2015. Power Market Design beyond 2020: Time to Revisit Key Elements?
- Newbery, D., Neuhoff, K., 2008. Market design for large shares of renewables: time and space, EPRG Spring Seminar, Cambridge.
- Niyimbona, P., 2005. The Challenges of Operationalizing Power Pools in Africa, UNDESA Seminar on Electricity Interconnection
- Northwest Power Pool, 2015. Reserve Sharing Program Documentation
- NREL, 2012. Overview of Western Renewable Energy Markets and Transmission Planning
- NREL, 2013. Market Evolution: Wholesale Electricity Market Design for 21st Century Power Systems
- Oren, S., 2000. Capacity Payments and Supply Adequacy in Competitive, VII Symposium of Specialists in Electric Operational and Expansion Planning
- Pérez Arriaga, J.I., Ruester, S., Schwenen, S., Batlle, C., Glachant, J.-M., 2013. From distribution networks to smart distribution systems: Rethinking the regulation of European DSOs. Think Final Report (<http://think.eui.eu>), European University Institute.
- Perez-Arriaga, I.J., 2012. Managing large scale penetration of intermittent renewables. MIT.
- Perez-Arriaga, I.J., Batlle, C., 2012. Impacts of intermittent renewables on electricity generation system operation. Economics of Energy and Environmental Policy 1.
- Pérez-Arriaga, I.J., Bhartkumar, A. 2014. A Framework for Redesigning Distribution Network Use of System Charges Under High Penetration of Distributed Energy Resources: New Principles for New Problems
- Potomac Economics, 2013, ERCOT State of the Market Report 2012.
- Potomac Economics, 2015, ERCOT State of the Market Report, 2014
- PwC (2015): A European comparison of electricity and gas prices for large industrial consumers, PricewaterhouseCooper, Frankfurt am Main.
- Rautkivi, M. and Arima, K. 2014, “Market Design to Reveal the Value of Flexibility”, Powergen Europe 2014
- Rebours, Y.G. et al. 2007. Survey of Frequency and Voltage Control Ancillary Services - Part II Economic Features, EEI Transactions on power systems, 22:1
- Riesz J., Gilmore, J. and Gill, M., 2015. Frequency Control Ancillary Service Market Design, The Electricity Journal, 28:3
- Riesz, J, 2013. Will Australia’s energy-only market work with high renewables?
- Riesz, J. and MacGill, I, 2013. 100% Renewables in Australia: Will a Capacity Market be Required?
- Riesz, J. and Milligan, M. 2015. Designing electricity markets for variable renewables, WIREs energy and Environment
- Roques, F. 2008. Market design for generation adequacy: Healing causes rather than symptoms, Utilities Policy, Elsevier, vol. 16:3, pages 171-183
- Sáenz de Miera, G., del Río González, P., Vizcaíno, I., 2008. Analysing the impact of renewable electricity support schemes on power prices: The case of wind electricity in Spain. Energy Policy 36, 3345-3359.
- Sandiford, Mike, Tim Forcey, Alan Pears & Dylan McConnell (2015): “Five Years of Declining Annual Consumption of Grid-Supplied Electricity in Eastern Australia: Causes and Consequences”, The Electricity Journal 28(7), 96-117.

- Sherwood, L., 2012. U.S. Solar Market Trends 2012, IREC
- Smart Energy Demand Coalition, 2011. The Demand Response Snap Shot The Reality For Demand Response Providers Working In Europe Today
- Smeers, Y., 2008. Study on the general design of electricity market mechanisms close to real time. Commissioned by: The Commission for electricity and Gas Regulation (CREG).
- Sovacool, B.K., 2009. The intermittency of wind, solar, and renewable electricity generators: Technical barrier or rhetorical excuse? Util Policy 17, 288-296.
- Synapse, 2015. Utility Performance Incentive Mechanisms: A Handbook for Regulators
- The Tellus Institute, 2000. Best Practices Guide: Integrated Resource Planning For Electricity
- ThinkSpain, 2015. Competition Commission fines Iberdrola €25 million for manipulating market
- Vandezande, L., Meeus, L., Belmans, R., Saguan, M., Glachant, J.M., 2010. Well-functioning balancing markets: A prerequisite for wind power integration. Energy Policy 38, 3146-3154.
- Vegh, G., 2014. OPA-IESO merger, Canadian Energy Perspectives
- Weber, C., 2010. Adequate intraday market design to enable the integration of wind energy into the European power systems. Energy Policy 38, 3155-3163.
- WECC 2013. Balancing Authority Cooperation Concepts – Intra-Hour Scheduling
- WECC 2013. Balancing Authority Cooperation Concepts to Reduce Variable Generation Integration Costs in the Western Interconnection: Intra-Hour Scheduling
- Wind Power Monthly, 2015, CfD payments to be withheld during negative pricing
- Wolak, F.A., 2000. Market design and price behavior in restructured electricity markets: an international comparison (pp. 127-152). Springer US.

11. ACRONYMS DEFINITION

Acronyme	Definition
2DS	2 Degree Scenario
AEMO	Australian Energy Market Operator
AUD	Australian Dollar
BA	Balancing Authority
BDEW	Bundesverband der Energie- und Wasserwirtschaft
CAPEX	Capital expenditure
CCS	Carbon Capture and Storage
CEER	Council of European Energy Regulators
CHP	Combined Heat and Power
COB	California-Oregon Border
CREZ	Competitive Renewable Energy Zones
CWE	Central West Europe
DG	Decentralised Generation
DSM	Demand-Side Management
DSO	Distribution Network Operator
DSR	Demand-Side Response
EEX	European Energy Exchange
EMR	Electricity Market Reform
EPS	Emissions Performance Standards
ERCOT	Electric Reliability Council of Texas
ETP	Energy Technology Perspectives
EU	European Union
EUR	Euro
FERC	Federal Energy Regulatory Commission
FIP	Feed-In Premium
FIT	Feed-In Tariff
FTI-CL	FTI-Compass Lexecon
GW	Gigawatt
IAEW	Institut für Elektrische Anlagen und Energiewirtschaft
ICE	Intercontinental Exchange

Acronyme	Definition
IEA-RETD	International Energy Agency's Implementing Agreement for Renewable Energy Technology Deployment
IESO	Independent Electricity System Operator
IPP	Individual power producer
IREC	International Renewable Energy Congress
ISE	Integrated Systems Europe
ISMO	Independent Market and Systems Operator
ISO	independent system operator
kW	Kilowatt
LCOE	Levelised cost of electricity
LOLP	loss of load probability
MMO	Market Maker Obligation
MPC	Market Price Cap
MW	Megawatt
NEM	National Electricity Market
NREL	National Renewable Energy Laboratory
OATT	open access transmission tariff
OECD	Organisation for Economic Co-operation and Development
OPA	Ontario Power Authority
OPEX	Operating expenditure
ORDC	Operating Reserve Demand Curve
OTC	Over the counter
PBR	Performance-Based Regulation
PJM	Pennsylvania New Jersey Maryland
PNM	Public Service Company of New Mexico
PSG	Project Steering Group
PUC	Public Utilities Commission
PV	Photovoltaics
PWC	PricewaterhouseCoopers
REMIT	Regulation on Energy Market Integrity and Transparency
RES	Renewable energy source
RIIO	Revenue=Incentives+ Innovation+Outputs

Acronyme	Definition
SA	South Africa
SMR	State of the Market Report
SRMC	Short Run Marginal Costs
TIPS	Trade and Industrial Policy Strategies
TSO	Transmission System Operator
UK	United Kingdom
UNDESA	United Nations Department of Economic and Social Affairs
US	United States
VAT	Value-Added Tax
VIK	Verband der Industriellen Energie- und Kraftwirtschaft
VOLL	Value of Lost Load
VRE	Variable renewable energy
WECC	Western Electricity Coordinating Council
WI	Western Interconnection

MEMBER COUNTRIES OF THE IEA RETD TECHNOLOGY COLLABORATION PROGRAMME

Supported by:



on the basis of a decision
by the German Bundestag





The **International Energy Agency's Renewable Energy Technology Deployment Technology Collaboration Programme (IEA RETD TCP)** provides a platform for enhancing international cooperation on policies, measures and market instruments to accelerate the global deployment of renewable energy technologies.

IEA RETD TCP aims to empower policy makers and energy market actors to make informed decisions by: (1) providing innovative policy options; (2) disseminating best practices related to policy measures and market instruments to increase deployment of renewable energy, and (3) increasing awareness of the short-, medium- and long-term impacts of renewable energy action and inaction.

Current member countries of the IEA RETD Technology Collaboration Programme (TCP) are Canada, Denmark, France, Germany, Ireland, Japan, Norway, and United Kingdom.

More information on the IEA RETD TCP can be found at

www.iea-retd.org